

EBRO Module System
for electric quarter-turn actuators



Example illustration, not all possible type variants are shown!

Original – assembly instructions
with operating manual and technical appendix

In accordance with EC Machinery Directive
2006/42/EG

Language version: English

Contents





	Page
A) GENERAL	4
A1 EXPLANATION OF SYMBOLS	4
A2 CORRECT USE	4
A3 DESIGN AND FUNCTION	5
A4 IDENTIFICATION OF THE ACTUATOR	6
A5 TRANSPORT AND STORAGE	7
B) ASSEMBLING THE ACTUATOR ONTO THE VALVE AND ELECTRICAL CONNECTION	8
B1 SAFETY NOTICES FOR ASSEMBLY AND CONNECTION	8
B2 INTERFACES	9
B3 INDIVIDUALLY SUPPLIED ACTUATOR: ASSEMBLING ONTO THE VALVE	9
B4 ASSEMBLY AND ADJUSTMENT	9
B5 ALL ACTUATORS, CONNECTION TO POWER SUPPLY AND THE CONTROL	10
B6 ALL ACTUATORS: ADJUSTMENT OF THE <CLOSED> AND <OPEN> POSITIONS	10
B7 ALL ACTUATORS, TRIAL RUN: TEST STEPS TO CONCLUDE ASSEMBLY AND CONNECTION	12
B8 ADDITIONAL INFORMATION: DISMANTLING THE ACTUATOR	12
C) OPERATING INSTRUCTIONS	13
C1 SAFETY NOTICES FOR OPERATION	13
C2 ELECTRICAL OPERATION/MANUAL OPERATION	13
C3 TROUBLESHOOTING	14
D) TECHNICAL APPENDIX	15
D1 NOTES ON PROJECT PLANNING	15
D1-1 ADAPTATION TO THE VALVE	15
D1-2 ACTUATOR OUTPUT TORQUES	15
D1-3 VALVE ASSIGNMENT	15
D1-5 WIRING DIAGRAMS AND WIRING SUGGESTIONS	16
D1-6 PROTECTION CLASS	16
D1-7 CORROSION PROTECTION	16
D1-8 DUTY CYCLE	16
D1-9 INSTALLATION POSITION	16
D1-10 THREE-POINT CONTROL	17
D1-11 EMERGENCY MANUAL OVERRIDE	17
D2 ELECTRICAL CONNECTION	17
D2-1 CONNECTOR TERMINALS	17
D2-2 GROUNDING/SAFETY EARTH	17
D2-3 SUPPLY VOLTAGE	18
D2-4 TORQUE CUT-OFF	18
D2-5 SWITCH BOX HEATER	18
D2-6 THERMAL MOTOR PROTECTION	18
D2-7 TYPE PLATE CODE	18

D3	MAIN BOARD PL.E71-LC FOR THE EBRO MODULE SYSTEM	19
D3-1	LIMIT SWITCHES S1 & S2	19
D3-2	ADDITIONAL LIMIT SWITCHES S3 & S4 (OPTIONAL)	19
D3-3	SWITCH BOX HEATER (230 V AC, 5 W)	19
D3-4	TORQUE CUT-OFF	19
D3-5	CONTROL AND FEEDBACK TERMINAL X9	20
D3-6	LOCAL CONTROL (OPTIONAL)	20
D3-7	CURRENT FEEDBACK 4–20 MA (OPTIONAL)	20
D3-8	MAIN BOARD PL-E71-LOCAL	21
D4	POSITIONER PL.E71-POS FOR THE EBRO MODULE SYSTEM	21
D4-1	POSITIONER (OPTIONAL)	21
D4-2	POSITIONER PL-E71-POS	23
D5	COMMISSIONING OF THE MAIN BOARD PL.E71-LC	23
D6	COMMISSIONING THE POSITIONER PL.E71-POS	24
D7	COMMISSIONING OF THE CURRENT FEEDBACK 4–20 MA (OPTIONAL)	24
D7-1	FACTORY SETTINGS FOR THE MAIN BOARD PL.E71-LC	25
D7-2	FACTORY SETTINGS FOR POSITIONER PL.E71-POS	25
E	TECHNICAL DATA FOR THE M71-WS-XXX-40 MODULES	26
E1	AREA OF USAGE	26
E2	STANDARD EQUIPMENT	26
E3	FLANGES AND BUSHES FOR E65 WS	26
E4	FLANGES AND BUSHES FOR E110 WS	26
E5	FLANGES AND BUSHES FOR E160 WS	26
E6	OPTIONS	27
F	TECHNICAL DATA FOR THE ACTUATORS	28
F1	ADDITIONAL TECHNICAL DATA	29
F2	TECHNICAL DATA FOR THE MODULES M71-DS-XXX-40	33
F3	TECHNICAL DATA FOR THE ACTUATORS	35
F4	ADDITIONAL TECHNICAL DATA	36
F5	DC ACTUATORS WITH BATTERY PACK	46
F6	TECHNICAL DATA	47
F7	ADDITIONAL TECHNICAL DATA	48
DECLARATION OF CONFORMITY WITH EC DIRECTIVES		54

A) General

A1 Explanation of symbols

In this operating manual, notes are marked with the following symbols:

 xxxxxxxx	Danger/Warning ... indicates a situation of immediate danger that could lead to death or severe injury if not avoided.
	Note ... indicates an instruction that should be obeyed without fail.
	Information ... indicates useful tips and recommendations.
	Danger/Warning ... hot surfaces are to be expected.

A2 Correct use

Electrical quarter-turn actuators of type E50 to E210 are intended for use as follows:

- with electrical power supply and control signals from a system-side control,
- in ambient conditions between -20°C and $+70^{\circ}\text{C}$ (EBRO standard),
- for actuating valves with 90° turn (e.g. flap valves or ball valves) using
 - ▶ 230 (or 115 or 24) V AC, 50/60Hz, or
 - ▶ 400 V 3-phase, 50 Hz, 60 Hz or
 - ▶ 24 V DC

into <OPEN> or <CLOSED> or intermediate positions.

Actuators for valves which, due to their design, must be moved into a tightly closed position with torque, can also be controlled load-dependently – for wiring proposals, see section D4.

This standard equipment found in the actuator can also protect the valve's functional parts from overloading.

- The actuators have a defined actuating time, suitable for continuous operation in accordance with EN15714-2 Table 1, Category C.
A correctly connected and adjusted drive system must correctly indicate the position of the valve with its electrical signals and with its optical display, and must as a rule close in a clockwise direction (looking at the valve drive shaft) and open in an anticlockwise direction.
- The integrated hand wheel allows easy manual operation (in case of power failure) at approx. 14–15 revolutions and a normal level of manual exertion.
The self-locking reduction gear of the actuator can lock the valve in any position in idle state.

The actuator's output torque and actuating time must be adapted to the valve, and its electrical design must be adapted to the control.

The actuator may only be operated in accordance with the following documents:

- the <Manufacturer's Declaration of Conformity with EC Directives> included in the delivery
- these EBRO assembly instructions (also included in the delivery).

The safety instructions in sections B1 and C1 must be observed when installing and operating the actuator.



The choice of wiring proposal to be used depends on the type of valve and on the intended purpose of the actuator. In general: this must be decided upon and selected accordingly by the planner/purchaser of the actuator. Typical wiring proposals for common applications can be found in section D4. The relevant terminal diagram is attached to the inside of the switching space cover of each actuator.

Note 1:

This manual should preferably be used in conjunction with the manual for the valve to which the actuator is fitted – with the manual for the valve **taking precedence**.

Note 2:

The planner/purchaser is responsible for attaching the actuator to the valve. Appendix B of Design Standard EN15714 - 2 provides detailed information in this regard. The actuator design should allow for a 10% undervoltage (see section D2.2 in the Appendix).

A3 Design and function

E65 up to E210 quarter-turn actuators (featuring an M71-XS-XXX-40 module) are designed to automate butterfly valves when the valve is required to deliver a modulating service.

They are constructed for a 90° actuation stroke.

The construction of the actuator has been designed as a unit assembly system. This principle is the same for all actuators in this series.

A single-phase or three-phase motor drives the actuators using high-efficiency asynchronous technology. All motors are thermally protected.

Connected to multiple spur gears, the output torque is transmitted to a self-locking worm gear. All gear parts are separately encapsulated and lubricated for life.

The worm gear is of self-locking design, ensuring that the valve disc remains in the position reached at the time when the motor power supply was switched off.

The mechanical interface with the valve is a standardised flange connection in accordance with EN ISO 5211.

Flexible interchangeable drive bushes accommodate different valve shaft sizes.

A further mechanical interface is situated between the gear housing and the switch box. The switch box contains the P.C.B. main board, where all standard functions for the actuator drive are carried out and various additional options can be easily added.

The operating cam is driven by the worm gear allowing easy adjustment of the orientation of the actuator. The operating cam forms the connection between the mechanical rotary movement and the electrical control.

The position indicator is located above the operating cam, offering permanent optical valve position indication. This applies for both electrical and manual operation.

When the actuator is installed on the valve, there is a gap between the valve and the actuator flange. This can be used for leakage detection.

A4 Identification of the actuator

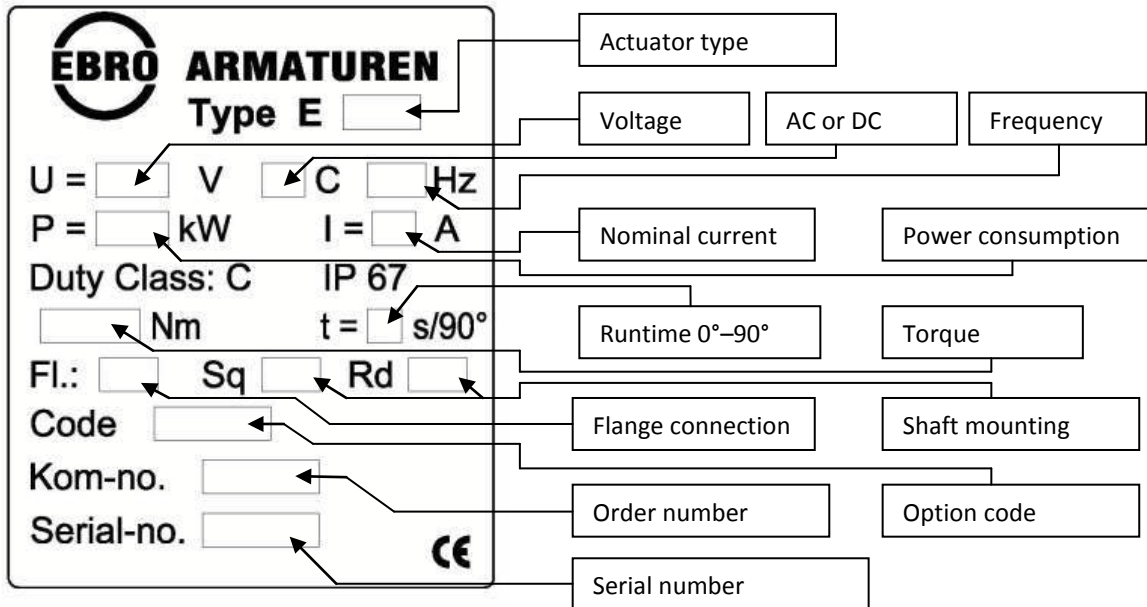

Each actuator is identified with the following type plate:
Key for 7-character code **MM YY ABC** on the type plate:



	Limit switch/cam	Functional options	Contacts
MM Production month	0 S1 & S2 for 0–90°	0 -	0
YY Production year	1 S1–S4 for 0–90°	1 Torque cut-off	G Gold contact
Code figure A Operating cam & limit switch design	2 S1 & S2 for 0–90° S3 & S4: freely adjustable	2 Potentiometer:	I Initiator
Code B Functional options	3 S1–S4: freely adjustable	3 Current feedback	A AS-i bus
Code C Contact type	4	4 Actuating time extension	
	5	5 Torque cut-off and potentiometer	
	6	6 Torque cut-off and current feedback	
	7 S1 & S2: freely adjustable	7 Actuating time extension (AC) and potentiometer	
	8	8 Actuating time extension (AC) and current feedback	
	9 Customer specification	9 Customer specification	

The type plate on the actuator housing must not be covered after assembling the actuator onto the valve and after installation in the pipe run – this is to ensure that the actuator remains identifiable.

A5 Transport and storage

	To avoid corrosion damage to electrical components during storage, the actuators should generally be stored at constant room temperature.
	If an actuator is already fitted to a valve: The transport and storage requirements in the valve manual apply. In all cases, the unit is to be stored at a constant temperature in an enclosed area.



For the correct transport of an individually supplied actuator, the following applies:
 Always observe the symbols on the packaging when transporting the packages.
 Keep the actuator in the factory packaging until it is put to use (fitted to the valve).
 Always place the actuator on its flat side – the motor or hand wheel should be positioned at the top or on the side.
 Store the actuator at a constant temperature and protect it from dirt and moisture.
 If required, use securing belts as a transport aid.

	When fitting a belt, ensure that it is not fastened to the hand wheel. Protect the actuator from any possible damage during transport.
---	---

B) Assembling the actuator onto the valve and electrical connection

This section provides all the information required for assembling an actuator onto a valve. The user is required to take account of the type-specific requirements of the valve (butterfly, ball valve) for the operation of the actuator.

B1 Safety notices for assembly and connection

	<p>The assembly and electrical/electronic connection of an actuator to the operator's system(s) must be carried out by trained specialists. For the purposes of this manual, trained specialists are persons who, on the basis of their training, specialist knowledge and professional experience, are familiar with high and low voltage electrical components and can correctly assess and execute the work assigned to them and can identify and avoid potential dangers.</p> <p>A knowledge of the typical properties of quarter-turn valves (butterflies, ball valves) is also required for the installation; assembly and connection should, where appropriate, be carried out in collaboration with expert colleagues.</p> <p>Voltage configuration: control and feedback contacts are designed for 250 V AC, motor supply contacts for 400 V AC as per EN 61010-1. An overvoltage protector must be provided in the electrical system. This should comply with the requirements of Overvoltage Category II and Pollution Severity 2.</p> <p>Conductor cross-sections of 0.2–2.5 mm² can be connected.</p> <p>Wiring can be carried out using plug-in connectors.</p> <p>The connectors should only be plugged in or unplugged when the power is off. All power supply systems must be equipped with the required overcurrent protection.</p> <p>Related values are given in the technical data table in section D5.</p> <p>A power-off switch must be installed. It should be installed close to the actuator and clearly marked.</p> <p>After installation, all wiring inside the wiring compartment of the actuator should be protected against displacement.</p> <p>In accordance with EN 61010-1, the feed lines must fulfil the requirements for reinforced conductor insulation within the pipe for the voltage proof test.</p> <p>The earth/PE terminal is provided between the two cable inlets at the earthing screws (M4). Switch box lid, motor and gear housing are earthed during manufacture.</p>
 Risk of crushing!	<p>The motor control contactors must be configured in accordance with DIN VDE 660, Section 102, Usage Category AC3, which defines the control requirement for inductive loads</p> <p>In order to avoid incorrect messages in the operator control or inaccurate signals from the torque cut-off, it must be ensured that the electrical cut-off of the actuator occurs after a maximum of 50 ms after reaching the limit switch.</p> <p>If the actuator is exposed to changing ambient temperatures, the switching space heating element must be connected to the power supply as soon as possible in order to prevent damage due to condensation in the switching space.</p> <p>Commissioning of an actuator assembled to a valve is not permitted until the valve is enclosed on both sides by a section of pipe or section of apparatus – any prior actuation will result in a risk of crushing and is the sole responsibility of the user.</p>

B2 Interfaces

The purchaser must ensure the compatibility of the following interfaces:

Actuator/valve flange connection: with dimensions according to ISO 5211 (actuator and/or valve may have multiple bores),

Valve drive shaft/borehole, square socket/parallel key in actuator:

- ▶ Form (= square or with parallel key) must match,
- ▶ The valve manufacturer must have defined the appropriate actuator shaft dimensions and tolerances on the valve shaft.

B3 Individually supplied actuator: assembling onto the valve

Use the hand wheel to move the actuator – appropriate to the position of the valve – into the <CLOSED> or <OPEN> position (maximum 15 revolutions are required), place on the valve and centre at the actuator/valve interface.

The actuator can be positioned as desired onto the valve and can be determined during assembly on-site.

The screw connection must be tightened sufficiently for the actuating torque to be transmitted by frictional forces – see table below. The flange size for the actuator is specified on the type plate. Tighten screws cross-wise.

ISO flange size	F04	F05	F07	F10	F12	F16
Tightening torque [Nm]	5–6 Nm	8–10 Nm	20–23 Nm	44–48 Nm	78–85 Nm	370–390 Nm

B4 Assembly and adjustment

Depending on the delivery status of the actuator, there are certain steps that must be followed before commissioning the actuator.

If the actuator and valve have been delivered completely assembled, all settings and tests will already have been carried out.

If the actuator has been delivered separately from the valve, the following requirements must be met.

In general, actuator assembly should be carried out with the valve closed.

The actuator is then assembled onto the valve and the two components are screwed together.

The switching space cover is removed.



Afterwards, the commissioning instructions described in chapters D5 to D7 are to be followed chronologically and step for step.

Correct functionality is to be tested once again by means of an electrical test run.

To ensure safety and maintain the protection class, all work should be carried by qualified electricians only.

B5 All actuators, connection to power supply and the control



The technical data for the actuators E65 - E210/WS/DS/GS can be found in section D5. The relevant terminal diagram is attached to the inside of the switching space cover of each actuator.

	When making a connection, it must be ensured that the system data – nominal voltage, control voltage (and frequency) – match the data specified on the actuator type plate.
	Section D4 of the Appendix – on selection of the wiring proposal (connection diagram) – specifies that the connection diagram selected must be suitable for the function of the valve and the actuator equipment. The planner/purchaser is responsible for selecting a suitable layout, which must be implemented in the system-side control.
	The actuator motor must always be powered down upon reaching the end position. This can be implemented directly via the limit switches (see wiring proposal on P. 24) or using the customer's controller. Three-phase actuators must be connected to the power supply with a <clockwise rotating field>, in order to ensure the correct direction of rotation for the actuator.

To connect to the control, unscrew the switching space cover. Conductor cross-sections of 0.2–2.5 mm² can be connected. The cables can also be installed in mated condition. Wiring or connection/disconnection of terminals must be carried out with the equipment powered down.

Different potentials are permitted within a cable, provided that the cable is designed for the maximum occurring voltage and current.

The actuator has M20x1.5 screwed cable glands for all supply and control cable entries:

	<i>To ensure protection class IP67 according to EN60529:</i> ▶ When shipped, all cable connection openings are sealed with plugs. The cable glands must not be inserted until connecting the control. ▶ Correct positioning of all seals on the switching space cover and the cable glands Only cables with Ø 6–13 mm sheathing are permitted.
	If the actuator is installed outside or in damp locations, the switching space heater must be put into operation immediately (power supply to terminals X3.1/X3.2)

B6 All actuators: Adjustment of the <CLOSED> and <OPEN> positions

This section is only applicable if the valve manufacturer has supplied the actuator separately and was thus not able to adjust the <CLOSED> and <OPEN> positions exactly.

The operating cam in the actuator is adjusted for the <CLOSED> position ex-works: If required:
Switching space cover must be open, remove position indicator and loosen the hex socket/Allen screw: Adjust operating cam as follows:

	The closed valve is the reference point for adjustment. In this position, the operating cam must be adjusted so that limit switch S1 is actuated. The operating cam is then resecured. In the standard design, the <OPEN> position will then be reached automatically. Do not use the hand wheel!
---	--

The <CLOSED> end position of the valve:

► Ensure that the electrical cut-out via the limit switches occurs before an (fixed or adjustable) end stop is reached in the valve.



The actuator itself also has mechanical fixed stops.

Once again, it must be ensured that the electrical cut-off via the limit switches occurs before the integrated fixed stop is reached. There should be play of at least 1/2 hand wheel revolution between electrical cut-out point and the fixed stop.

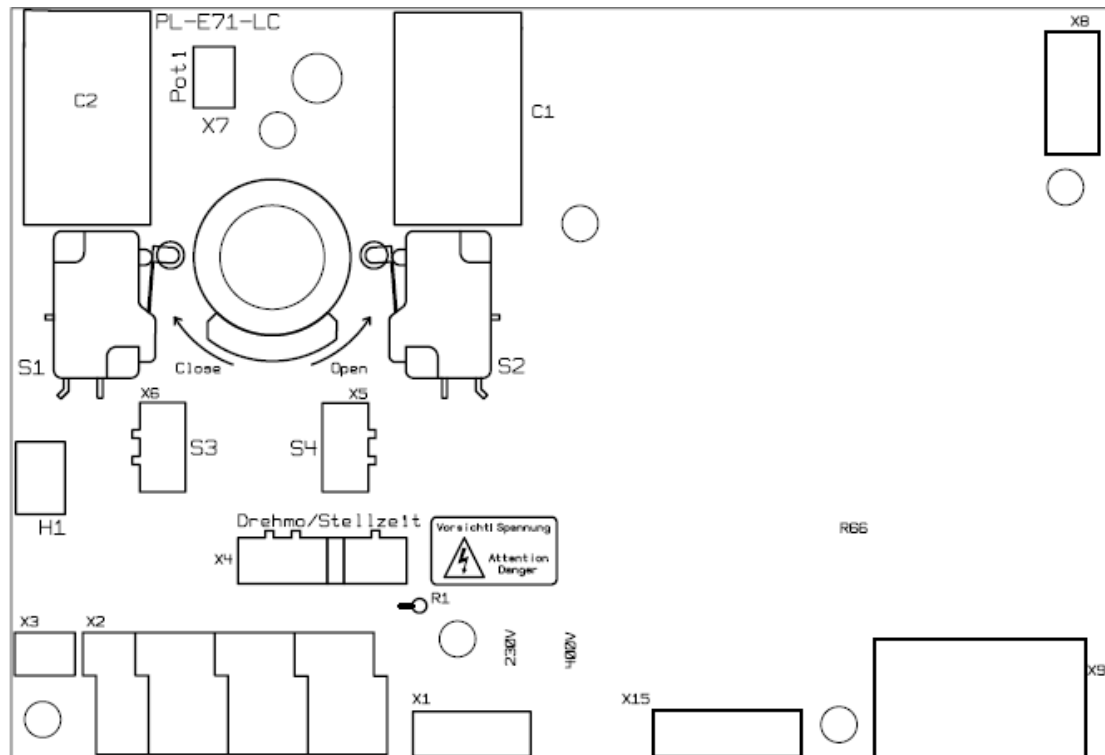

Fix the adjusted operating cam with the hex socket/Allen screw.

Place and adjust the position indicator.
Check the electrical functions of the actuator.



Actuators with special equipment in the switching space:

Additional limit switches (S3 and S4, optional) must always be set as leading to guarantee signalling before motor cut-out.

Before assembling the switching space cover, ensure that the O-ring seal is correctly fitted.

B7 All actuators, trial run: test steps to conclude assembly and connection

To conclude the assembly process, check the functionality and control of the actuator:

Does the position indicator on the actuator match the valve position?

If not, the indicator position must be readjusted (at least) – see B5 above.

 Danger	<p>Incorrect position feedback (and incorrect optical display) presents a danger for subsequent operation.</p>
--	--

Has the correct connection diagram been used?

The <Close> control signal must move the valve into the tight <CLOSED> position:

Depending on the type of valve, this must be done using the limit switch (typical: Ball valves and butterfly valves with with rubber lining) or through load-dependent switch-off (typical for butterfly valves with metal seal).

Remedy: see section C3: Troubleshooting.

Check actuating function and display:

When nominal voltage is present, the control commands “**CLOSED**” and “**OPEN**” must cause the valve to move **into the corresponding end positions**. The optical display on the actuator or on the valve must show this correctly.

If this is not the case, the actuator control and/or the indicator position must be corrected accordingly.

If all electrical position indicators are correct:

Electrical feedback for the “**OPEN**” and “**CLOSED**” display must be compared with the optical display on the valve. **Signal and display must agree.**

If this is not the case, the control and/or the adjustment of the position indicator must be checked.

B8 Additional information: dismantling the actuator

The same safety regulations are to be observed as for the pipeline system, the power supply and the (electrical) control system.

Carry out the following steps:

Mark the alignment between actuator and valve position and record it for reassembly.

Interrupt the power supply safely – if necessary, depressurise the valve.

Disconnect power supply and control cable.



Loosen the actuator/valve flange connection and remove the actuator from the valve.

C) Operating instructions

This manual contains all of the necessary information for operating an actuator which has been assembled onto a valve.

It is assumed when assembling and connecting to the control that the connection diagram has been adapted to the type-specific requirements of the valve (butterfly, ball valve) during operation of the actuator – also see sections B and D.

C1 *Safety notices for operation*

	<p>The functioning of a valve-mounted electrical actuator must comply with the <Correct use>, which is described in section A2.</p> <p>The conditions of use must comply with the conditions shown on the actuator type plate.</p> <p>Standard actuators are to be operated exclusively within the permitted temperature limits of –20 and +70°C.</p> <p>After correct assembly and adaptation to the valve, the actuator is maintenance-free for continuous operation in Class C as per EN 15714-2.</p> <p>All maintenance to be carried out on the actuator is to be completed by trained specialists only. For the purposes of this manual, trained specialists are persons who, on the basis of their training, specialist knowledge and professional experience, can correctly assess and execute the work assigned to them and can identify and avoid potential risks.</p>
 Risk of crushing!	<p>Operation of an actuator mounted on a valve is only permissible if the valve is enclosed on both sides by a section of pipe or equipment – any prior actuation entails a risk of crushing and is the sole responsibility of the user.</p>

Additional note

- In accordance with MRL 2006/42/EC, the system planner must complete a comprehensive risk analysis. The manufacturer EBRO Armaturen makes the following documents available for this purpose:
- Assembly instructions in accordance with EC Machinery Directive 2006/42/EC – see section B of this manual
- Checklist for actuator-typical risks – see section D6.

C2 *Electrical operation/manual operation*

If the actuator is correctly assembled as described in section B, it will work automatically and is designed to be maintenance-free for operating mode <C>, in accordance with EN15714-2, Table 1.

The actuator can be manually operated in non-electrical mode at any time, without the need for conversion; this requires only a normal level of manual exertion (also see EN12570).

C3 Troubleshooting

When attempting to eliminate malfunctions, you can use the following table to check whether to search for the fault in the actuator or in its control, or if a malfunction of the valve needs to be identified:

Typical fault characteristic	Possible cause	Notes/action to be taken
Actuator will not start	Thermal overcurrent switch has triggered	Only applies for DC actuators
	Thermal switch has triggered	For AC and 3-phase actuators; resets automatically after cooling down
Motor gets very hot	Duty cycle too long	Check cycle times
	Incorrect wiring	Compare existing wiring with recommended wiring diagrams
	Incorrect rotary field	Apply clockwise rotating field
	Mechanical stop has been reached before the limit stop becomes active	Adjust operating cam
Torque cut-off actuates	Check valve torque	Compare with manufacturer's data
	Valve torque too high	Compare with manufacturer's data
	Chosen setting too low	Adjust torque cut-off
	Actuator hitting mechanical stop	Adjust operating cam
Actuators "hunting"	Blockage in pipe	Check valve and pipe
	Non-permissible parallel connection	Electrically decouple actuator controls from each other
Control contacts stick/burn	Inadequate dimensioning of load circuit relays	Use control contactor with switching category AC3
Condensation forming in actuator	Heating not connected	Permanently supply heating with voltage
	Seal set or screwed cable gland defective	Check and correct if necessary

D) Technical appendix

Note:

This appendix is not a part of the <Original Assembly Instructions>, it simply provides supplementary information. The planner/purchaser must ensure that the actuator is suitable for

- ▶ the valve on which it is assembled,
- ▶ the system-side power supply and the control system.

Important relevant technical information in this respect is listed below.

D1 Notes on project planning

D1-1 Adaptation to the valve

Electric actuators E65 up to E210 (featuring M71-XS-XXX-40 module) can be installed to drive 90° turn valves with standardised flange connections according to EN ISO 5211.

In general, the actuator is switched off via the integrated travel limit switches S1 and S2, which turn off the power supply to the motor. Torque-dependent switch-off control is only possible when this is allowed by the relevant valve design.

D1-2 Actuator output torques

The output torques given for the actuators are rated torque values. These will be achieved under all operating conditions when the supply voltage is equal to the rated voltage. This is valid for actuators under drive conditions.

Voltages of up to 10% over the rated voltage are permissible.

D1-3 Valve assignment

The main factors influencing the required actuation torque of the valves are the nominal size, the working pressure and the medium. The required actuation torque for the valve is derived from these parameters. It is recommended that a safety reserve of 15% to 20% is added to the value specified by the valve manufacturer for the design of the actuator.

The nominal torque of the actuator must be higher than the operating torque of the valve plus the safety reserve in order to guarantee fault-free operation.

D1-4 Control response

The control response for the actuators is parallel to the pivot path of the valve. In order to position the valve disc as precisely as possible and, therefore, to achieve the optimal control response for the actuator, the longest possible actuation time should be selected.

D1-5 Wiring diagrams and wiring suggestions

The wiring diagrams shown for the actuators (M71-WS-016-40 or M71-DS-016-40) show fully equipped actuators including all optional components. In other words, the equipment on the actuator delivered may have one or more fewer optional components. Thus the required effort for wiring the actuator will be correspondingly less. A currently valid version of the wiring diagram is usually delivered with the actuator. The version will be coded in accordance with the module number and provided on the type plate. There is also information provided about the wiring diagram number and the relevant components on the actuator in the selection tables on pages 24 and 32.

The wiring suggestions show options for possible actuator control. They provide an illustration of the easiest way to commission an actuator. In general, setting up the actuator control is the operator's responsibility. This applies to the professional installation, wiring technology and observance of the required on-site safety regulations.

D1-6 Protection class

The actuator series E65 up to E210 (featuring M71-XX-XXX-40) module are environmentally protected in accordance with EN IEC 60529, protection class IP67.

In addition, the switch box heater should be used when the actuator is operated outdoors or in rooms with high humidity.

It is the responsibility of the operator to ensure that all electrical and mechanical installations are carried out in a competent way as this is essential for compliance with protection class IP 67.

D1-7 Corrosion protection

The electric actuators have successfully passed a salt spray test according to EN 60068-2-52 that meets the requirements of Germanischer Lloyd

The testing parameters were set at severity 4 and carried out for a period of 14 days.

Therefore, the actuators are suitable for operation in industrial plants and other areas with average saline concentration.

This unit corresponds to corrosion category C4, as set out in the EN 15714-2 standards for industrial applications.

D1-8 Duty cycle

The actuators E65 to E210 fulfil duty class C according to EN 15714-2.

Classes A and B are covered by class C.

Class C covers:

E65	with 1200 starts per hour
E110	with 600 starts per hour
E160	with 600 starts per hour
E210	with 300 starts per hour

The duty cycle decreases by approx. 10% at the maximum ambient temperature.

D1-9 Installation position

The position in which the actuator is installed can be freely defined.

D1-10 Three-point control

The actuators E65 up to E210 are equipped with a self-locking worm gear. This keeps the actuator in the same position even when the power supply has been switched off. This is true for the end positions and all intermediate positions. This means that pressure from the medium cannot influence the valve disc position.

D1-11 Emergency manual override

The manual override is a revolving hand wheel that acts directly on the worm gear without a clutch. This enables the user to close or open the valve without a clutch mechanism at any time with just a few turns of the hand wheel.

The safety regulations for revolving hand wheels according to EU directive 89/392 are fulfilled. EN 15714-2 defines that the valve must be closeable by turning the hand wheel in a clockwise direction.

Preassembled valve and actuator assemblies are factory set with the correct hand wheel rotation.

It is the customer's responsibility to ensure that separately purchased actuators have the correct rotation when installed.

D2 *Electrical connection*

D2-1 Connector terminals

All connector terminals on the main board are designed for the maximum permissible voltage. Control and feedback contacts are designed for 250 V AC and motor supply contacts for 400 V AC as per EN 61010-1. An overvoltage protector must be provided in the electrical system. This should comply with the requirements of Overvoltage Category II and Pollution Severity 2.

Conductor cross-sections of 0.2–2.5 mm² can be connected.

Wiring can be carried out using plug-in connectors.

The connectors should only be plugged in or unplugged when the power is off. All power supply systems must be equipped with the required overcurrent protection. Related values are given in the technical data table.

A power-off switch must be installed. It should be installed close to the actuator and clearly marked.

After installation, all wiring inside the wiring compartment of the actuator should be protected against displacement.

In accordance with EN 61010-1, the feed lines must fulfil the requirements for reinforced conductor insulation within the line for the voltage proof test.

All necessary work on the electric actuators should be carried out by qualified electricians only.

D2-2 Grounding/safety earth

Four M4 ground screws are available between the four cable glands for the safety earth connection. Switch box lid, motor and gear housing are earthed during manufacture.

D2-3 Supply voltage

Single-phase actuators

All actuators – E65 WS up to E160 WS (featuring M71-WS-XXX-40 module) – must be permanently supplied with 230V AC (L1 and N).

Three-phase actuators

All actuators – E65 DS up to E210 DS (featuring M71-DS-XXX-40 module) – must, as a rule, be permanently supplied with 400 V AC. It must be ensured here that the voltage supply to X1 (L1, L2 and L3) is connected with a clockwise rotating field. If the wrong field orientation is applied, it will lead to the malfunction of the actuator.

D2-4 Torque cut-off

The potential-free contact of the torque cut-off will trigger, when the preset torque value is exceeded.

The torque cut-off generates a signal pulse, which is continuous until the power to the motor has been switched off.

The switching off of the power supply to the motor after the torque cut-off has been triggered must be realised on-site. Possibilities for integrating the torque cut-off switch into the control concept are shown in our wiring diagram suggestions.

D2-5 Switch box heater

The switch box heater should be installed on actuators that are exposed to highly fluctuating ambient temperatures. This is necessary to prevent the build-up of condensation inside the actuator.

The switch box heater must be permanently powered independently of the control and motor power supplies.

D2-6 Thermal motor protection

Single-phase and three-phase actuators are equipped with thermal protection switches embedded in the motor windings. When the motor temperature exceeds the maximum allowable temperature, it disconnects and interrupts the power supply to the motor. The thermal protection switch automatically resets itself once the motor has cooled down sufficiently.

D2-7 Type plate code

For identification of electrical equipment inside the actuator, there is a code with 6 characters on the type plate with the following structure: MM YY AB

MM for month of manufacture

YY for year of manufacture

A for the limit switch design

B for functional options

C for contact design

The characters A, B, and C are each coded with a 0.

The configuration of the actuator is completely coded in the module number (M71-XS-XXX-40). (See pages 33 and 40)

D3 Main board PI.E71-LC for the EBRO Module System

All components described below are located on the main board of the EBRO Module System. The main board contains limit switches for end position control, digital remote control inputs via a controller, as well as an electronic power amplifier for controlling the motor. In addition, the main board provides 5 status feedback relays, an interface for local control switches and an integrated interface for connecting a positioner.

D3-1 Limit switches S1 & S2

The limit switches S1 and S2 determine the switch-off points for the OPEN and CLOSED positions. S1 determines the CLOSED position. S2 determines the OPEN position. These two switches have the highest priority in the entire control hierarchy. They cannot be deactivated by remote control signals or local control signals. When a limit switch is reached, the motor will be switched off for this drive direction. The switches are wired internally on the PCB. There is no external access via connector X2.

D3-2 Additional limit switches S3 & S4 (optional)

The switches S3 and S4 (**max. 250 V AC, 3A**) can be installed as an option. They can be used to provide additional potential-free feedback signals or as intermediate switches for the purpose of signalling within the pivot path. If used as additional limit switches, it is important to note that S3 and S4 must be set to trigger before S1 or S2 become active. It must be ensured that the signals from S3 or S4 have occurred before the power supply to the motor is switched off by S1 or S2. The electric contactors for S3 and S4 can be attached at terminal X2.

D3-3 Switch box heater (230 V AC, 5 W)

The switch box heater prevents condensation from forming inside the switch box housing. It must be permanently supplied with power. The supply voltage must be applied on contactor X3. The switch box heater must be connected when the actuator is subjected to large temperature fluctuations, as is the case for outdoor use. This is also true for rooms with high levels of humidity. Operation of the heater is the responsibility of the operator. The manufacturer's guarantee will become invalid in cases where the conditions of use have not been followed.

D3-4 Torque cut-off

The EBRO module system also has an electronic torque cut-off. It offers a potential-free contact on terminal X2. This contact becomes active when the set torque value is exceeded. The torque cut-off generates a signal pulse, which is continuous until the power to the motor has been switched off. Once the torque cut-off has been triggered, it must be ensured that the power supply to the motor is then also switched off.

The switching off of the power supply to the motor after the torque cut-off has been triggered must be realised on-site. Possibilities for integrating the torque cut-off switch into the control concept are shown in our wiring diagram suggestions.

D3-5 Control and feedback terminal X9

The control and feedback terminal X9 offers various possibilities for convenient actuator control. There is a wired-out 24 V DC power supply that can be used for operator control applications. This power supply is fused internally and its max. load is 50 mA.

There are 2 potential-free remote control inputs for the actuator drive directions OPEN and CLOSED. They can be driven with max. 30 V DC. Current consumption is 5 mA. The correct signal polarity must be observed.

There are 5 status feedback relays, set up as voltage-free changer contacts. All base contacts for these feedback relays are connected with one other.

The following signals can be evaluated;

Position CLOSED reached:	S1 activates
Position OPEN reached:	S2 activates
Automatic mode selected:	Actuator can be driven by remote control signals or by positioner
Manual mode selected:	Actuator can be driven only by local control (only possible when local control switches are installed)
Multiple error signal:	In the case of power failure or a control signal drop-out at the positioner when switched to "zero-life mode" (Attention: This contact is active during normal operating conditions. It will be triggered when an error is detected)

D3-6 Local control (optional)

The EBRO module system can be equipped with local control as an option. This local control contains two switches. One switch determines the operation mode: automatic, local or neutral. This switch is lockable in each selected position and can be secured with a pad lock – ensuring it is protected against unauthorised access. If automatic mode is selected and no positioner is installed, the actuator can be driven by remote input control signals at connector X9. Should a positioner be installed, the actuator drive direction is determined by analogue input signals at the positioner. When the positioner is installed, remote signal inputs at X9 are deactivated. The second switch is used to control the desired position: OPEN or CLOSED. This switch is only active when local mode is selected.

D3-7 Current feedback 4–20 mA (optional)

In order to provide continuous feedback about the position of the valve, a potentiometer with downstream converter technology can be optionally installed. The current feedback is realised using two-wire technology and is potential-free. The current feedback works completely independently from all other electronic components inside the actuator and provides feedback on the actual disc position of the valve. The current feedback signal 4–20 mA can either be powered from an external source or make use of the internally generated 24 V DC power supply.

D3-8 Main board PI-E71-LOCAL

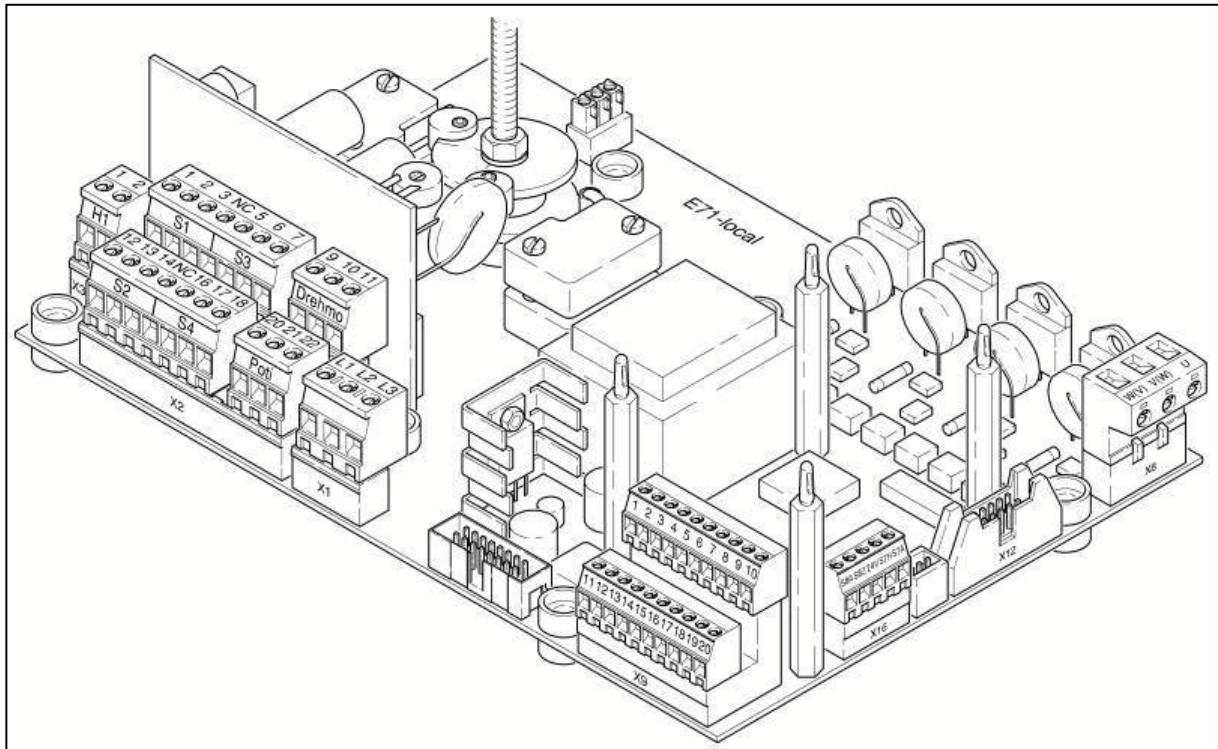

D4 Positioner PI.E71-POS for the EBRO Module System

D4-1 Positioner (optional)

The positioner can be deployed as an additional circuit board to the main board. The positioner enables the actuator to be operated as a controlled drive. There are some setting options on the board that are required for the controlled operation of the actuator.

The positioner is equipped with a separate voltage and current input as standard and also with a 0–10 V DC voltage feedback.

These signals

0–10 V or 2–10 V	at input U
0–20 mA or 4–20 mA	at input I
0–10 V feedback	at output UR

are available at terminal X1-POS.

There are 4 potentiometers available to adjust the control circuit board:

P1	Adjust the control hysteresis
P2	Adjust the CLOSED position
P3	Adjust the OPEN position
P4	Adjust the voltage feedback 0–10 V

Function switch S1 determines the working range area for the voltage and current input signals. When S1 is switched to position 0–20 mA, the current input works at 0–20 mA and the voltage input at 0–10 V.

When S1 is switched to position 4–20 mA, the current input works at 4–20 mA and the voltage input at 2–10 V.

The voltage feedback always works at 0–10 V, independent of the S1 setting.

Switch S2 determines the motor drive direction. It must be switched to position “=” for normal operation. This means that the lowest actuating signal is allocated to the CLOSED position.

In usage cases where the maximum actuation signal should be allocated to the CLOSED position, S2 needs to be switched to position “X”. For this type of operation, it is also necessary to exchange the red and green wires from the potentiometer with one another.

The circuit board also contains the jumper J1. This jumper can be plugged into three different positions. It allows the operator to determine the function of the actuator in case of a control signal drop-out. Jumper J1 is only active when S1 is switched to position 4–20 mA. If the actuation signal falls below 4 mA or below 2 V then the actuator will be switched to the predefined position set by the jumper. Should S1 be in position 0–20 mA or 0–10 V, then the jumper J1 is inactive.

For optical control during commissioning, the positioner is equipped with 3 LED's. D1 (green) signals operational readiness and lights up as soon as the actuator is connected to the power supply. It is also necessary for S1 to be switched to position 0–10 V or 0–20 mA.

If S1 is switched to position 2–10 V or 4–20 mA, the actuation signal must also be applied via Input U or Input I before D1 will light up.

The LED's D2 and D3 are drive direction indicators and light up when the positioner is controlling the relevant drive direction and the actuator is actively running. When the relevant end position has been reached and the allocated limit switch S1 or S2 on the main board PI.E71-LC has been activated then the corresponding LED will light up.

If the actuator is operating as a controlled drive and has reached the desired control point along the actuation path, the lights for D2 and D3 will be extinguished.

LED D2 indicates drive direction OPEN.

LED D3 indicates drive direction CLOSED.

Note: **When the positioner is installed, the remote control inputs at terminal X9 on the main board PI.E71-LC are switched off.**

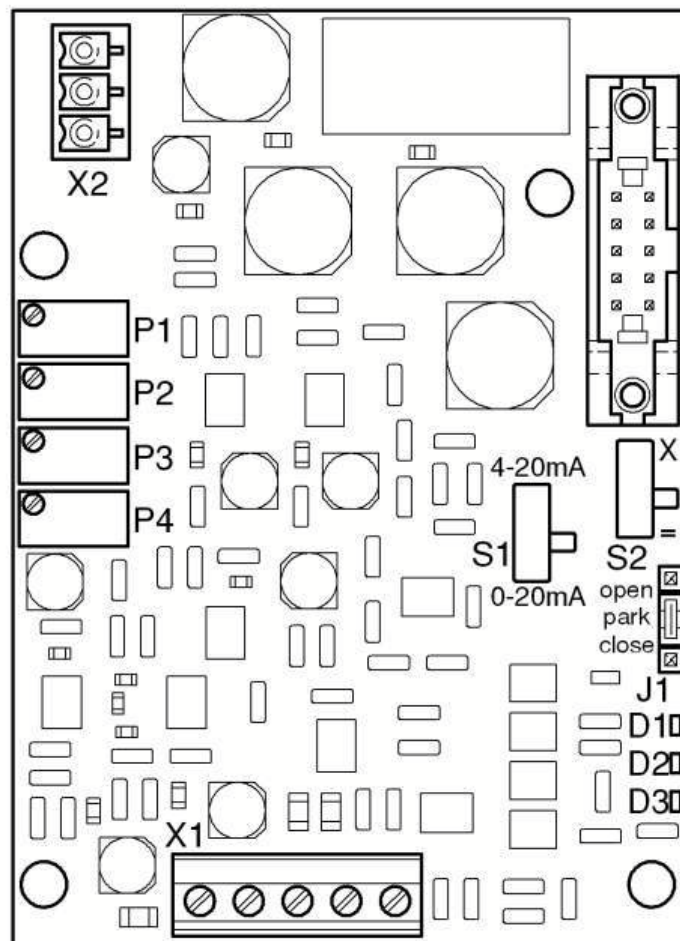
D4-2 Positioner PI-E71-POS**D5 Commissioning of the main board PI.E71-LC**

- The valve must be placed in the CLOSED position
- The actuator must also be placed in the CLOSED position (by turning the hand wheel clockwise until the mechanical end stop has been nearly reached)
- Assemble the actuator on the valve and screw it to the flange
- Open the actuator lid and remove the position indicator
- Loosen the lock nut on the contour disc that operates S1 and S2
- Adjust the contour disc so that S1 becomes active and fix in place again with the lock nut
- Reinstall the position indicator
- Connect power supply at X1

All necessary adjustments have now been completed and the actuator can be driven with the remote control inputs at X9.

When local control is installed, this can also be used to drive the actuator.

D6 Commissioning the positioner PI.E71-POS

Preconditions: Commissioning of the main board PI.E71-LC has been completed successfully

- The potentiometer must be aligned if the actuator is in the CLOSED position
- Measure the resistance between the black and green wires of potentiometer using an ohmmeter. When the minimum value between 5–10 ohms is displayed, fix the potentiometer pinion in place.
- Connect the potentiometer with the positioner
- Connect the power supply at connector X1
- Apply the minimum value of the actuation signal at connector X1-POS
- Check whether the operational range switch S1 on the positioner agrees with the control signal.
- Adjust P2 on the positioner in such a way that limit switch S1 on main board becomes activated and D3 is still just about lit.
- Apply the maximum value of the actuation signal to the positioner
- Adjust P3 on the positioner in such a way that limit switch S2 on the main board becomes activated and D2 is still just about lit
- P4 on the positioner determines the feedback voltage signal 0–10 V. When the limit switch S2 on the actuator is activated and D2 is still lit, adjust P4 until you measure 10 V DC on the output UR at connector X1-POS
- Apply the actuation signal (5 V or 10 mA) to the positioner
- Balance the actuator using P1 so that it does not oscillate (shuttle to and fro). Check the behaviour of the actuator by moving it out of the control point a few times by turning the hand wheel and ensure that the actuator returns back to the control point without oscillating.

D7 Commissioning of the current feedback 4–20 mA (optional)

Preconditions: Potentiometer adjustment has been completed successfully as described above.

The current feedback signal 4–20 mA works independently from all other electronic components. A dual potentiometer is used for detecting the position, which is adjusted by calibrating with the positioner.

Adjustment of the feedback signal is carried out using the two potentiometers P1 and P2 on the converter board (marking found on the soldering site of the main board).

When the actuator has been moved into the CLOSED position, adjust the 4 mA value using P1.

When the actuator is in OPEN position, adjust the 20 mA value using P2.

The voltage supply input and current output of this circuit board are located at terminal X2.

Note: The operations described above are necessary when the actuator and the valve have been delivered separately. If the actuator and the valve have been assembled in the factory then all settings and adjustments have already been completed.

D7-1 Factory settings for the main board PI.E71-LC

Limit switches S1 & S2 are adjusted for 90° pivot travel. S1 is responsible for switching off the actuator in the drive direction CLOSED. S2 is responsible for switching off the actuator in the drive direction OPEN.

D7-2 Factory settings for positioner PI.E71-POS

In general, the minimum control signal value is allocated to the CLOSED position. The maximum control signal value is allocated to the OPEN position.

- P1 The hysteresis of the controller is adjusted so that the actuator operates without oscillating.
- P2 Potentiometer P2 is adjusted so that the actuator activates limit switch S1 when the minimum control signal value is applied.
- P3 Potentiometer P3 is adjusted so that the actuator activates limit switch S2 when the maximum control signal value is applied.
- P4 Potentiometer P4 is adjusted so that 10 V DC is available at contact UR on terminal X1-POS when the actuator is in the OPEN position
- S1 Switch S1 is switched to position 0–20 mA. This setting gives a voltage input range determined for 0–10 V operation.
- S2 Switch S2 is switched to position “=”. This means that the actuator moves in the direction OPEN when the input signal is increased.
- J1 Jumper J1 is set to position STOP (only active in zero-life mode).

E Technical data for the M71-WS-XXX-40 modules

E1 Area of usage

The quarter-turn actuators E65 WS, E110 WS and E160 WS are designed for 90° pivot paths. They are used to automate butterfly valves, ball valves and other final control elements. Actuator can be controlled using potential-free digital inputs or standardized analogue control signals such as 0–10 V DC or 4–20 mA.

The actuators stand out due to their compact design and their practice-oriented handling in the areas of wiring system technology and commissioning. The modular construction of the actuators makes it as simple to retrofit or implement special functions. This is made possible thanks to the printed circuit board (P.C.B.), which is prepared above and beyond the standard functions to enable it to handle further components. These additional functions can, therefore, be implemented in a simple and cost-effective way.

E2 Standard equipment

- Main board PI.E71-LC with potential-free control terminals for the directions of travel OPEN and CLOSE via fully electronic motor power stages, 5 potential-free feedback status signals, interfaces for local control and positioner installation
- 2 integrated limit switches for actuator control (S1 and S2)
- Integrated thermal protection switch in the motor windings (S7)
- Integrated electronic torque cut-off
- Switch box heater
- Optical position indicator
- Clutch-free emergency hand wheel
- Mechanical end stops
- Epoxy resin coating

E3 Flanges and bushes for E65 WS

- F04, F05 and F07 according to EN ISO 5211
- Square bushes: 10 mm, 11 mm, 12 mm, 14 mm, 16 mm, 17 mm
- Round bushes: 16 mm with fitting key

E4 Flanges and bushes for E110 WS

- F07 and F10 according to EN ISO 5211
- Square bushes: 12 mm, 14 mm, 16 mm, 17 mm, 22 mm, 24 mm
- Round bushes: 28 mm with fitting key

E5 Flanges and bushes for E160 WS

- F10, F12 and F16 according to EN ISO 5211
- Square bushes: 17 mm, 22 mm, 24 mm, 27 mm and 32 mm
- Round bushes: 30 mm, 40 mm und 50 mm with fitting key

E6 Options

1. Additional potential-free limit switches (S3 and S4)
2. Freely adjustable intermediate switches (S3 and S4) for signalling within the travel parameters
3. Positioner
4. Current feedback 4–20 mA featuring dual-wire technology
5. Lockable local control
6. Proximity switches for signalling
7. Fusible thermal motor switch for multiple error signal
8. Special voltages

F Technical data for the actuators

E65 WS

Actuation time from 0° to 90°	s	6	12*	24*
Rated torque	Nm	100	80	60
Rated current	A	0.7	0.55	0.3
Starting current	A	1.0	0.8	0.4
Power consumption	kW	0.16	0.125	0.066
Rated voltage	V	230	230	230
Frequency	Hz	50	50	50
Duty cycle	Class C according to EN 15714-2			
Protection class	IP67 according to EN IEC 60529			
Weight in Kg	7			

* Option

E110 WS

Actuation time from 0° to 90°	s	6*	12	24*
Rated torque	Nm	400	400	320
Rated current	A	1.8	1.3	0.65
Starting current	A	2.6	2	1.5
Power consumption	kW	0.4	0.26	0.138
Rated voltage	V	230	230	230
Frequency	Hz	50	50	50
Duty cycle	Class C according to EN 15714-2			
Protection class	IP67 according to EN IEC 60529			
Weight in Kg	14			

* Option

E160 WS

Actuation time from 0° to 90°	s	12*	24	48*
Rated torque	Nm	1100	1100	750
Rated current	A	1.8	1.3	0.65
Starting current	A	2.6	2	2.5
Power consumption	kW	0.4	0.26	0.138
Rated voltage	V	230	230	230
Frequency	Hz	50	50	50
Duty cycle	Class C according to EN 15714-2			
Protection class	IP67 according to EN IEC 60529			
Weight in KG	25			

* Option

F1 Additional technical data

Limit switches:	max. 250 V AC, 3 A
Torque cut-off:	potential-free changer, max. 250 V AC, 5 A
Switch box heater:	supply 230 V AC permanent, 5 W
Potentiometer:	1000 Ω, 1 W, rotation angle 270°
Current feedback:	4–20 mA, supply max. 30 V DC
Thermal protection switch:	integrated
Insulation class:	F
Corrosion protection class:	C4 according to EN 15714-2, tested according to EN 60068-2-52
Cable glands:	4 x M20 x 1.5; \varnothing min = 6 mm; \varnothing max = 13 mm
Operating temperature:	-20°C to +70°C
Hand wheel:	15 revolutions for 90°
Hand wheel torque:	4 Nm for E65 20 Nm for E110 35 Nm for E160

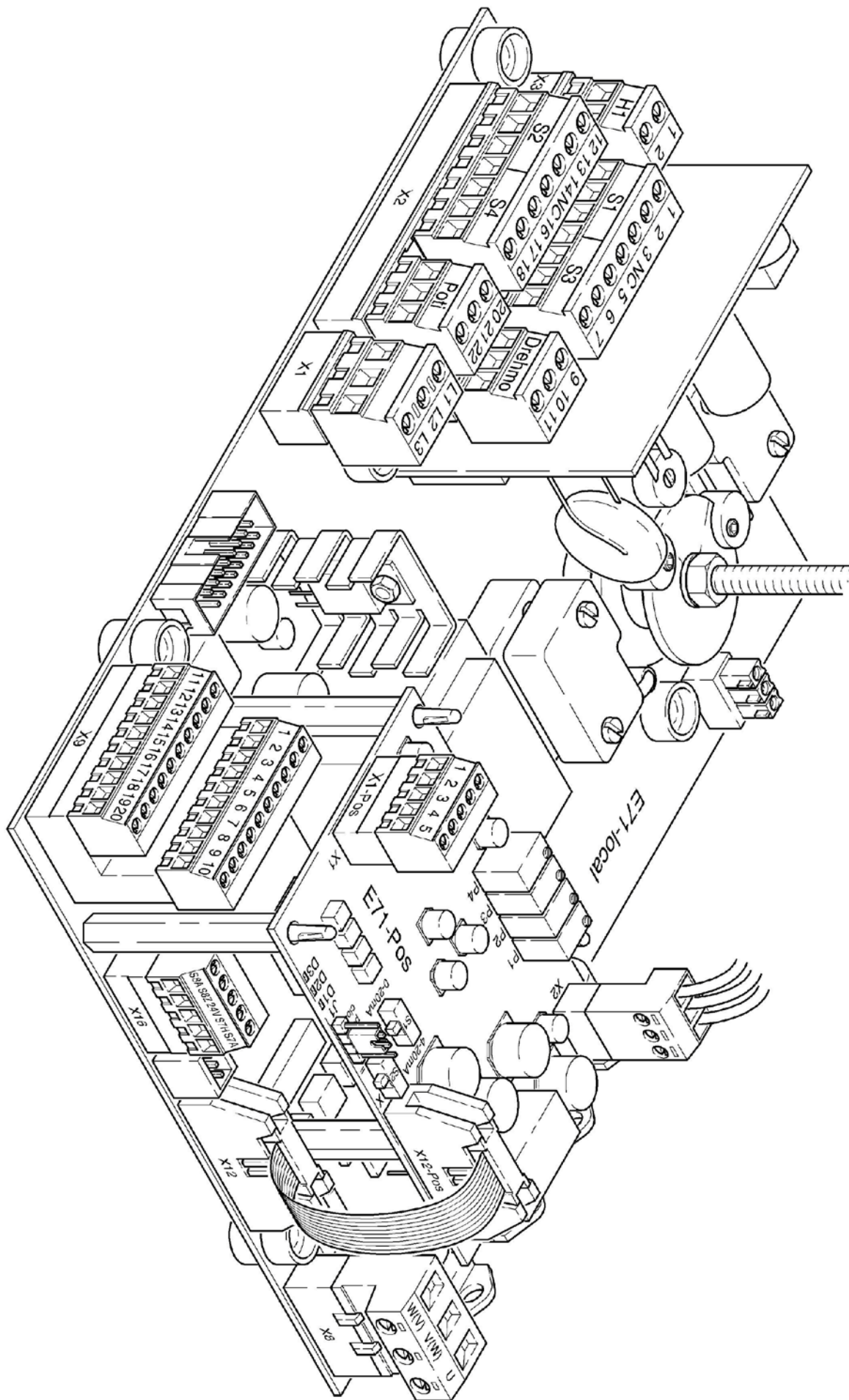

Connector table

Connector name	Description	Function
X1	X1.N	Neutral line
	X1.L1	Phase L1
	X1.	Not connected
X2	X2.1	Not connected
	X2.2	Not connected
	X2.3	Not connected
	X2.5	Switch S3; additional limit switch CLOSED; NC
	X2.6	Switch S3; additional limit switch CLOSED; COM
	X2.7	Switch S3; additional limit switch closed; NO
	X2.9	Torque cut-off opener; NC
	X2.10	Torque cut-off floor contact; COM
	X2.11	Torque cut-off closer; NO
	X2.12	Not connected
	X2.13	Not connected
	X2.14	Not connected
	X2.16	Switch S4; additional limit switch OPEN; NC
	X2.17	Switch S4; additional limit switch OPEN; COM
	X2.18	Switch S4; additional limit switch OPEN; NO
	X2.20	Potentiometer; end contact or current feedback output
X2.21	Potentiometer: collector bar	
X2.22	Potentiometer; end contact or current feedback input	
X3	X3.1	Switch box heater; U = 230 V AC permanent
	X3.2	Switch box heater; U = 230 V AC permanent
X8	X8.U	Motor connector
	X8.W	Motor connector
	X8.V	Motor connector
X9	X9.1	Supply voltage +24 V DC (max. 50 mA)
	X9.2	Ground supply voltage (GND)
	X9.3	Remote control signal OPEN (max. +30 V DC)
	X9.4	Ground remote control signal (GND)
	X9.5	Common contact of status relay (max. 24 V DC)
	X9.6	Status relay feedback position OPEN; NO
	X9.7	Status relay feedback position CLOSED; NO
	X9.8	Status relay feedback manual mode; NO
	X9.9	Status relay feedback automatic mode; NO
	X9.10	Status relay feedback multiple error feedback*; NO*
	X9.11	Supply voltage +24 V DC (max. 50 mA)
	X9.12	Ground supply voltage (GND)
	X9.13	Remote control signal CLOSED (max. +30 V DC)
	X9.14	Ground remote control signal (GND)
	X9.15	Common contact of status relay (max. 24 V DC)
	X9.16	Status relay feedback position OPEN; NC
X9.17	Status relay feedback position CLOSED; NC	
X9.18	Status relay feedback manual mode; NC	
X9.19	Status relay feedback automatic mode; NC	
X9.20	Status relay feedback multiple error feedback*; NC*	
X1-POS	X1.1	Voltage control input (+) 0–10 V
	X1.2	Current control input (+) 0–20 mA or 4–20 mA
	X1.3	Control input ground (GND)
	X1.4	Voltage position feedback (+) 0–10 V
	X1.5	Voltage position feedback ground (GND)

* Error feedback relay is active for normal operating conditions!

Wechselstromantriebe

Single-phase actuators

Ausstattung Equipment	Standard			Optionen / Options			
	Basisplatine PI.E71-Local Mainboard PI.E71-Local	Digitale Fernsteuereingänge Digital remote control inputs	Digitale Rückmeldungen Digital feedback outputs	Zusätzliche Endschalter Add. Limit switches	Stromrückmeldung 4-20mA Current feedback 4-20mA	Vorortsteuerung Local control	Positioner PI.E71-POS
Klemmenplan Wiring diagram							
M71-WS-001-40	X	X	X				
M71-WS-002-40	X	X	X	X			
M71-WS-003-40	X	X	X		X		
M71-WS-004-40	X	X	X			X	
M71-WS-005-40	X	X	X	X	X		
M71-WS-006-40	X	X	X		X	X	
M71-WS-007-40	X	X	X	X		X	
M71-WS-008-40	X	X	X	X	X	X	
M71-WS-009-40	X		X				X
M71-WS-010-40	X		X	X			X
M71-WS-011-40	X		X		X		X
M71-WS-012-40	X		X			X	X
M71-WS-013-40	X		X	X	X		X
M71-WS-014-40	X		X		X	X	X
M71-WS-015-40	X		X	X		X	X
M71-WS-016-40	X		X	X	X	X	X

Wenn der Positioner installiert ist, werden die Fernsteuereingänge abgeschaltet
When positioner is installed, remote control inputs are switched-off

F2 Technical data for the modules M71-DS-XXX-40

Area of usage

The quarter-turn actuators E65 DS, E110 DS, E160 DS and E210 DS are designed for 90° pivot paths. They are used to automate butterfly valves, ball valves and other final control elements. Actuator can be controlled using potential-free digital inputs or standardized analogue control signals such as 0–10 V DC or 4–20 mA.

The actuators stand out due to their compact design and their practice-oriented handling in the areas of wiring system technology and commissioning. The modular construction of the actuators makes it as simple to retrofit or implement special functions. This is made possible thanks to the printed circuit board (P.C.B.), which is prepared above and beyond the standard functions to enable it to handle further components. These additional functions can, therefore, be implemented in a simple and cost-effective way.

Standard equipment

- Main board PI.E71-LC with potential-free control terminals for the directions of travel OPEN and CLOSE via fully electronic motor power stages, 5 potential-free feedback status signals, interfaces for local control and positioner installation
- 2 integrated limit switches for actuator control (S1 and S2)
- Integrated thermal protection switch in the motor windings (S7)
- Integrated electronic torque cut-off
- Switch box heater

- Optical position indicator
- Clutch-free emergency hand wheel
- Mechanical end stops
- Epoxy resin coating

Flanges and bushes for the E65 DS

- F04, F05 and F07 according to EN ISO 5211
- Square bushes: 10 mm, 11 mm, 12 mm, 14 mm, 16 mm, 17 mm
- Round bushes: 16 mm with fitting key

Flanges and bushes for E110 DS

- F07 and F10 according to EN ISO 5211
- Square bushes: 12 mm, 14 mm, 16 mm, 17 mm, 22 mm, 24 mm
- Round bushes: 28 mm with fitting key

Flanges and bushes for E160 DS

- F10, F12 and F16 according to EN ISO 5211
- Square bushes: 17 mm, 22 mm, 24 mm, 27 mm and 32 mm
- Round bushes: 30 mm, 40 mm und 50 mm with fitting key

Flanges and bushes for E210 DS

- F10, F12 and F16 according to EN ISO 5211
- Square bushes: 24 mm, 27 mm and 32 mm
- Round bushes: 30 mm, 40 mm und 50 mm with fitting key

Options

1. Additional potential-free limit switches (S3 and S4)
2. Freely adjustable intermediate switches (S3 and S4) for signalling within the travel parameters
3. Positioner
4. Current feedback 4–20 mA featuring dual-wire technology
5. Lockable local control
6. Proximity switches for signalling
7. Fusible thermal motor switch for multiple error signal
8. Special voltages

F3 Technical data for the actuators

E65 DS

Actuation time from 0° to 90°	s	6	12*	24*
Rated torque	Nm	100	80	-
Rated current	A	0.3	0.25	-
Starting current	A	0.5	0.3	-
Power consumption	kW	0.085	0.065	-
Rated voltage	V	400	400	-
Frequency	Hz	50	50	-
Duty cycle	Class C according to EN 15714-2			
Protection class	IP67 according to EN IEC 60529			
Weight in Kg	7			

* Option

E110 DS

Actuation time from 0° to 90°	s	6*	12	24*
Rated torque	Nm	400	400	320
Rated current	A	1.4	1	0.95
Starting current	A	2.1	1.8	1.6
Power consumption	KW	0.27	0.22	0.2
Rated voltage	V	400	400	400
Frequency	Hz	50	50	50
Duty cycle	Class C according to EN 15714-2			
Protection class	IP67 according to EN IEC 60529			
Weight in Kg	14			

* Option

E160 DS

Actuation time from 0° to 90°	s	12*	24	48*
Rated torque	Nm	1100	1100	750
Rated current	A	1.4	1	0.95
Starting current	A	2.1	1.8	1.6
Power consumption	KW	0.27	0.22	0.2
Rated voltage	V	400	400	400
Frequency	Hz	50	50	50
Duty cycle	Class C according to EN 15714-2			
Protection class	IP67 according to EN IEC 60529			
Weight in Kg	25			

* Option

E210 DS

Actuation time from 0° to 90°	s	12*	24	48*
Rated torque	Nm	4000	4000	3200
Rated current	A	1.8	2.2	1.8
Starting current	A	2.6	3.2	3.2
Power consumption	kW	0.4	0.540	0.2
Rated voltage	V	400	400	400
Frequency	Hz	50	50	50
Duty cycle	Class C according to EN 15714-2			
Protection class	IP67 according to EN IEC 60529			
Weight in Kg	40			

* Option

F4 Additional technical data

Limit switches:	max. 250 V AC, 3 A
Torque cut-off:	potential-free changer, max. 250 V AC, 5 A
Switch box heater:	supply 230 V AC permanent, 5 W
Potentiometer:	1000 Ω, 1 W, rotation angle 270°
Current feedback:	4–20 mA, supply max. 30 V DC
Thermal protection switch:	integrated
Insulation class:	F
Corrosion protection class:	C4 according to EN 15714-2, tested according to EN 60068-2-52
Cable glands:	4 x M20 x 1.5; \varnothing min = 6 mm; \varnothing max = 13 mm
Operating temperature:	-20°C to +70°C
Hand wheel:	15 revolutions for 90°
Hand wheel torque:	4 Nm for E65 20 Nm for E110 35 Nm for E160 50 Nm for E210

Three-phase actuator with integrated direction control, positioner, local control, additional limit switches and current feedback 4-20mA

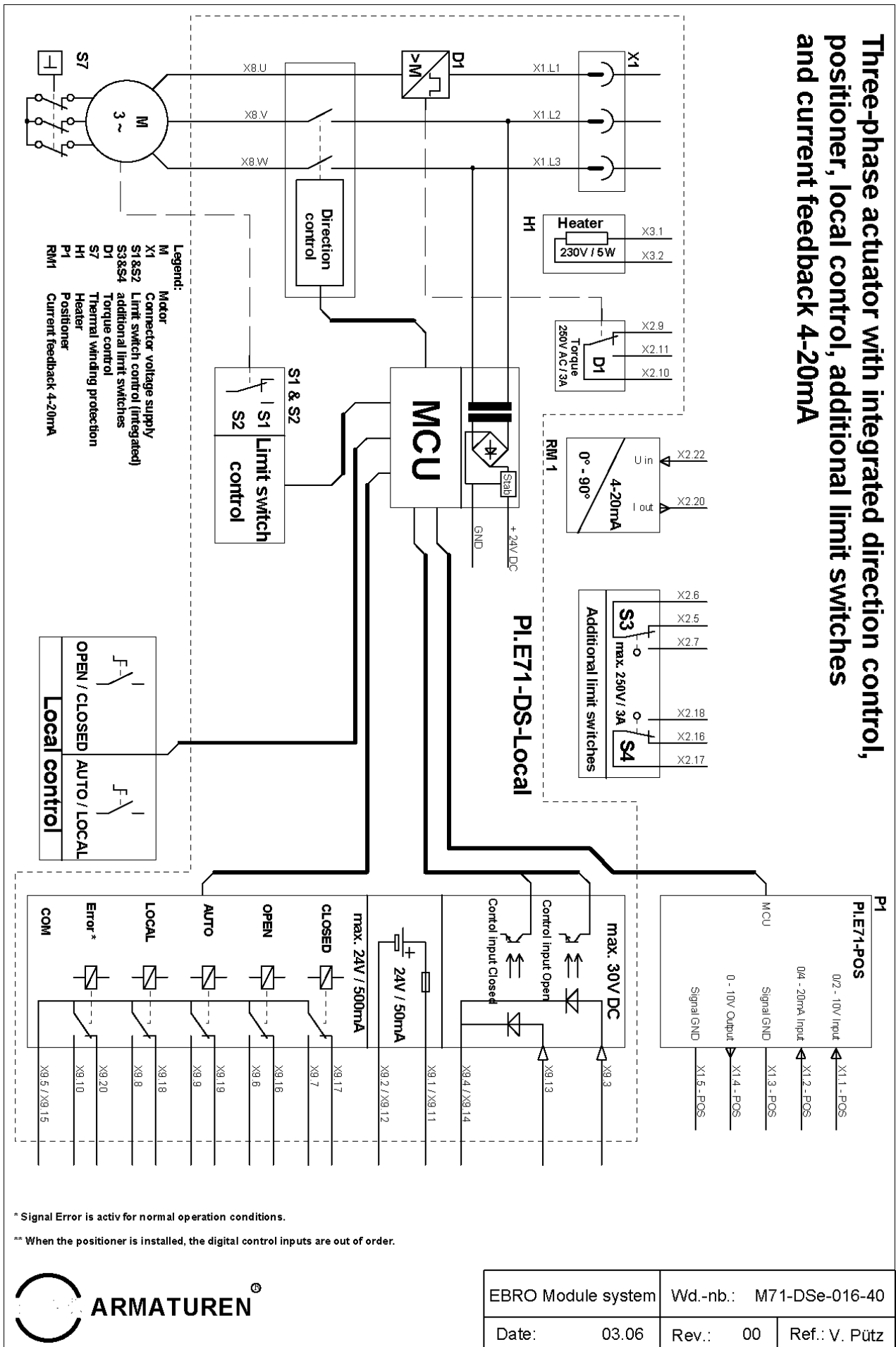

* Signal Error is activ for normal operation conditions.

** When the positioner is installed, the digital control inputs are out of order.



EBRO Module system	Wd.-nb.: M71-DSe-016-40
Date: 03.06	Rev.: 00 Ref.: V. Pütz

Connector table

Connector name	Description	Function
X1	X1.L1	Phase L1 (clockwise rotary field)
	X1.L2	Phase L2 (clockwise rotary field)
	X1.L3	Phase L3 (clockwise rotary field)
X2	X2.1	Not connected
	X2.2	Not connected
	X2.3	Not connected
	X2.5	Switch S3; additional limit switch CLOSED; NC
	X2.6	Switch S3; additional limit switch CLOSED; COM
	X2.7	Switch S3; additional limit switch CLOSED; NO
	X2.9	Torque cut-off opener; NC
	X2.10	Torque cut-off floor contact; COM
	X2.11	Torque cut-off closer; NO
	X2.12	Not connected
	X2.13	Not connected
	X2.14	Not connected
	X2.16	Switch S4; additional limit switch OPEN; NC
	X2.17	Switch S4; additional limit switch OPEN; COM
	X2.18	Switch S4; additional limit switch OPEN; NO
X3	X2.20	Potentiometer; end contact or current feedback output
	X2.21	Potentiometer; collector bar
X3	X2.22	Potentiometer; end contact or current feedback input
	X3.1	Switch box heater; U = 230 V AC permanent
X8	X3.2	Switch box heater; U = 230 V AC permanent
	X8.U	Motor connector
	X8.W	Motor connector
X9	X8.V	Motor connector
	X9.1	Supply voltage +24 V DC (max. 50 mA)
	X9.2	Ground supply voltage (GND)
	X9.3	Remote control signal OPEN (max. +30 V DC)
	X9.4	Ground remote control signal (GND)
	X9.5	Common contact of status relay (max. 24 V DC)
	X9.6	Status relay feedback position OPEN; NO
	X9.7	Status relay feedback position CLOSED; NO
	X9.8	Status relay feedback manual mode; NO
	X9.9	Status relay feedback automatic mode; NO
	X9.10	Status relay feedback multiple error feedback*; NO*
	X9.11	Supply voltage +24 V DC (max. 50 mA)
	X9.12	Ground supply voltage (GND)
	X9.13	Remote control signal CLOSED (max. +30 V DC)
	X9.14	Ground remote control signal (GND)
	X9.15	Common contact of status relay (max. 24 V DC)
	X9.16	Status relay feedback position OPEN; NC
	X9.17	Status relay feedback position CLOSED; NC
	X9.18	Status relay feedback manual mode; NC
	X9.19	Status relay feedback automatic mode; NC
X9.20	Status relay feedback multiple error feedback*; NC*	
X1-POS	X1.1	Voltage control input (+) 0–10 V
	X1.2	Current control input (+) 0–20 mA or 4–20 mA
	X1.3	Control input ground (GND)
	X1.4	Voltage position feedback (+) 0–10 V
	X1.5	Voltage position feedback ground (GND)

* Error feedback relay is active for normal operating conditions!

Drehstromantriebe

Three-phase actuators

Ausstattung Equipment	Standard			Optionen / Options			
	Basisplatine PL.E71-Local Mainboard PL.E71-Local	Digitale Fernsteuereingänge Digital remote control inputs	Digitale Rückmeldungen Digital feedback outputs	Zusätzliche Endschafter Add. Limit switches	Stromrückmeldung 4-20mA Current feedback 4-20mA	Vorortsteuerung Local control	Positioner PL.E71-POS
Klemmenplan Wiring diagram							
M71-DS-001-40	X	X	X				
M71-DS-002-40	X	X	X	X			
M71-DS-003-40	X	X	X		X		
M71-DS-004-40	X	X	X			X	
M71-DS-005-40	X	X	X	X	X		
M71-DS-006-40	X	X	X		X	X	
M71-DS-007-40	X	X	X	X		X	
M71-DS-008-40	X	X	X	X	X	X	
M71-DS-009-40	X		X				X
M71-DS-010-40	X		X	X			X
M71-DS-011-40	X		X		X		X
M71-DS-012-40	X		X			X	X
M71-DS-013-40	X		X	X	X		X
M71-DS-014-40	X		X		X	X	X
M71-DS-015-40	X		X	X		X	X
M71-DS-016-40	X		X	X	X	X	X

Wenn der Positioner installiert ist, werden die Fernsteuereingänge abgeschaltet
 When positioner is installed, remote control inputs are switched-off

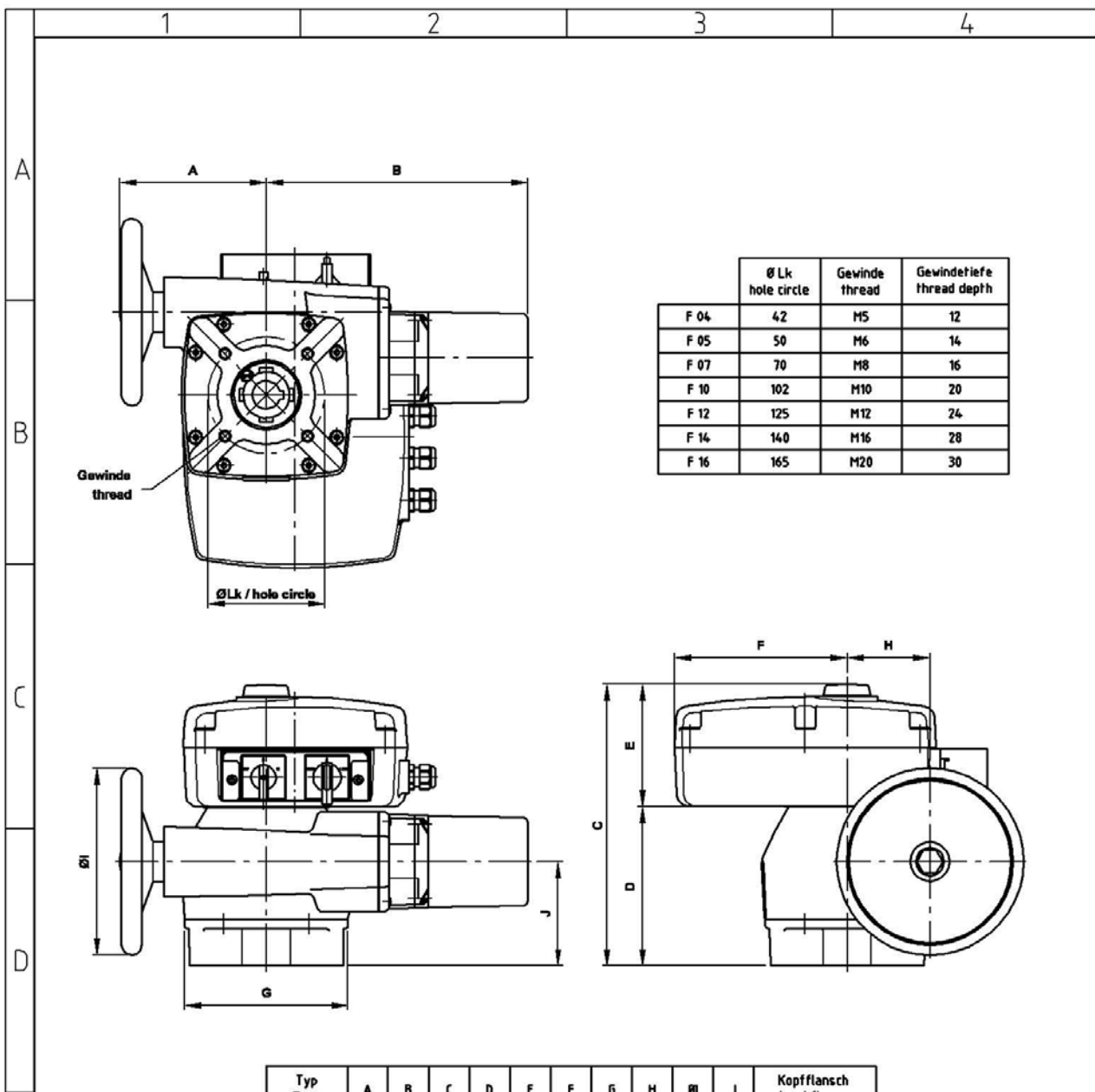

Typ Type	A	B	C	D	E	F	G	H	Øl	J	Kopfflansch head flange
E65	119	171	255	123	132	185	125	42	80	78	F04, F05, F07
E110	136	247	277	145	132	185	150	58	125	88	F07, F10
E160	157	280	302	170	132	185	175	89	200	112	F10, F12, F16
E210	212	352	294	162	132	185	240	125	315	84	F12, F14, F16

Werkstoff:				Maßstab 1:6		Gewicht kg		
				Zeichn. - Nr.: YXXE-000-0000-40				
				Datum 24.04.2006		Name M.Kreuh		
				Gepr.:		Elektro Antriebe mit ESK-1		
				Norm		Electric actuator with ESK-1		
				Schutzvermerk nach DIN 34				
				Allgemeintoleranz nach ISO 2768-m				
				Ers. f.:		Ers. d.:		
Zust.	Änderung	Datum	Name	VZ001YX001Y VZ001YX001Y VZ001YX001Y VZ001YX001Y VZ001YX001Y VZ001YX001Y				Blatt 00
							Bl	



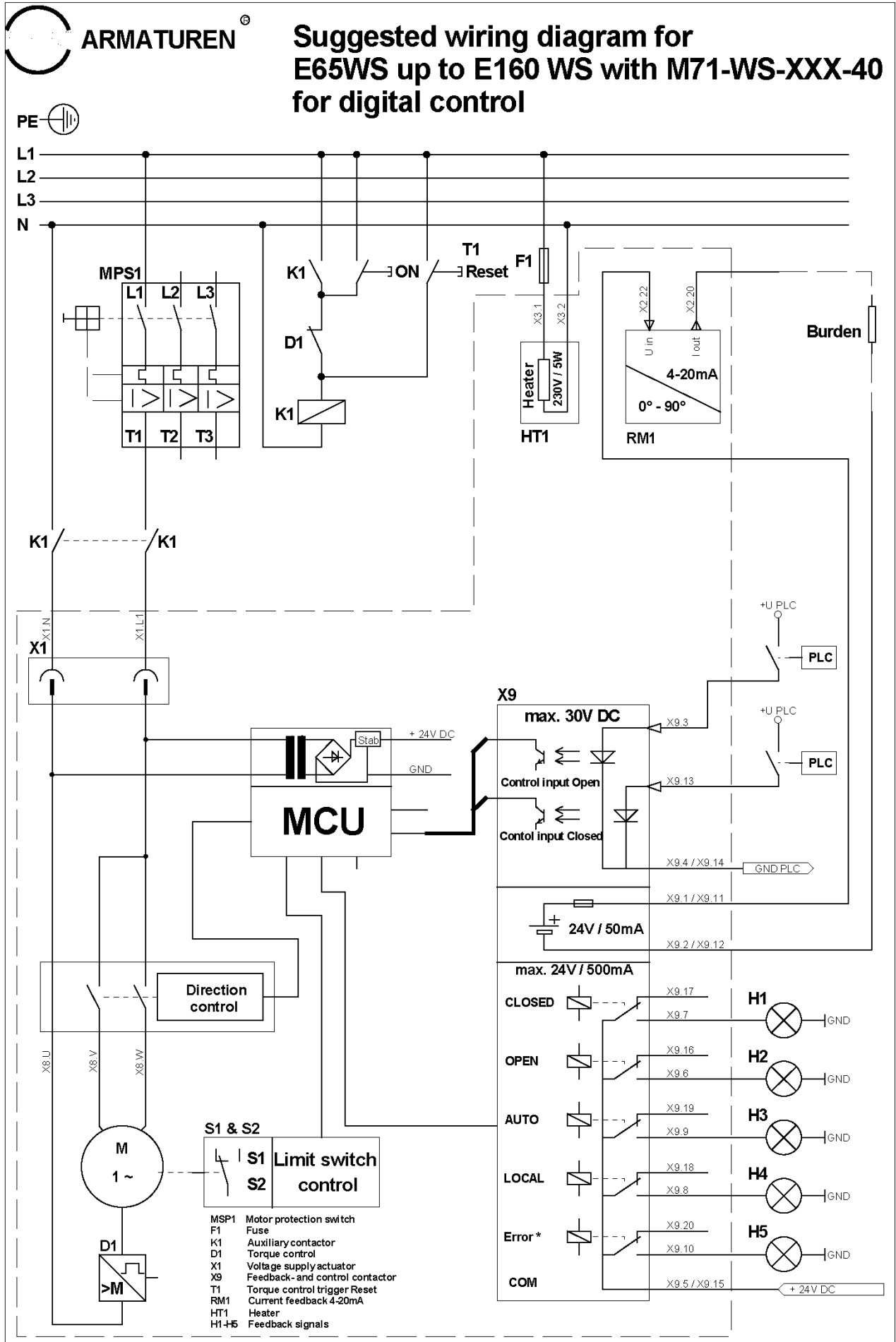

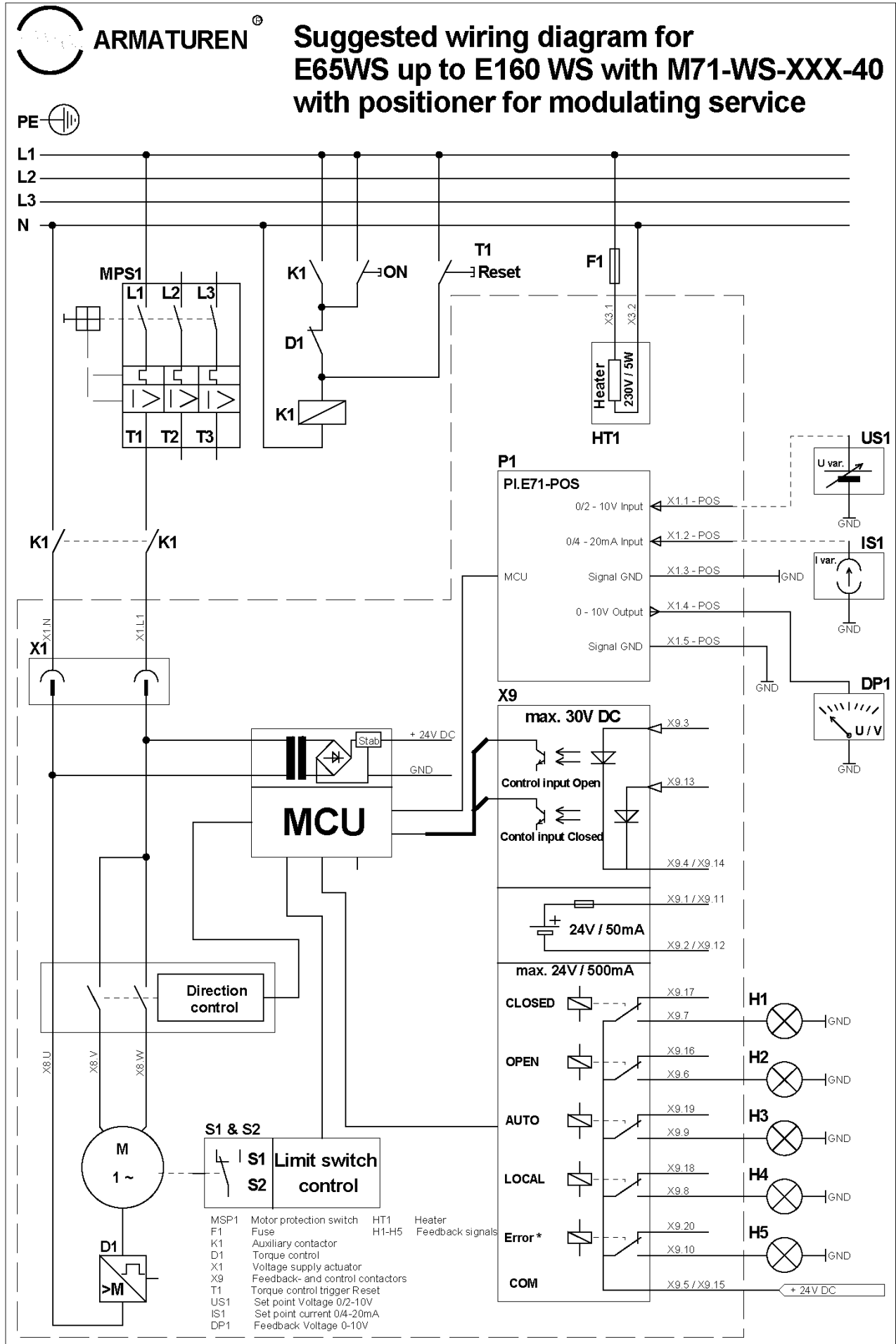

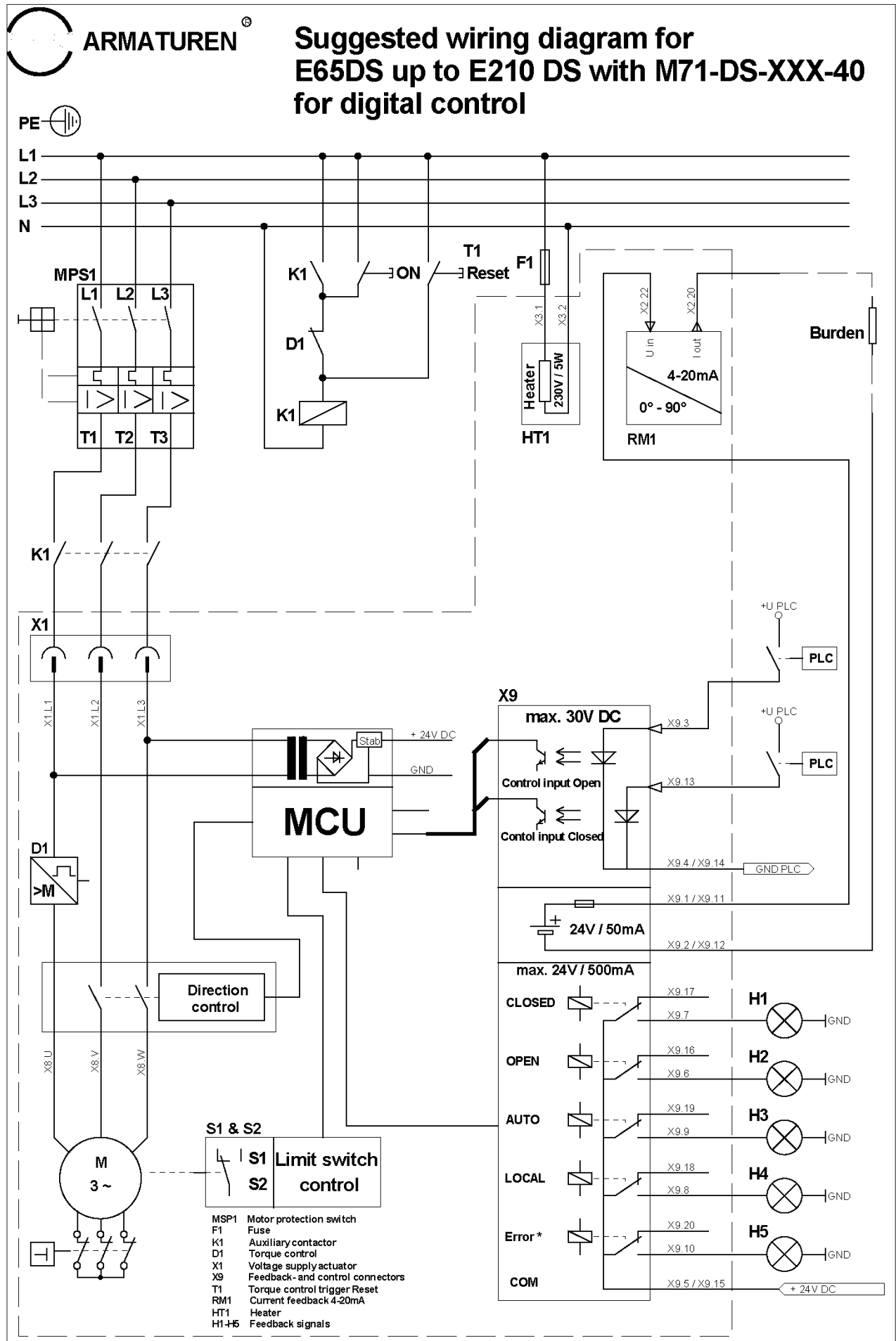



Suggested wiring diagram for E65DS up to E210 DS with M71-DS-XXX-40 with positioner for modulating service

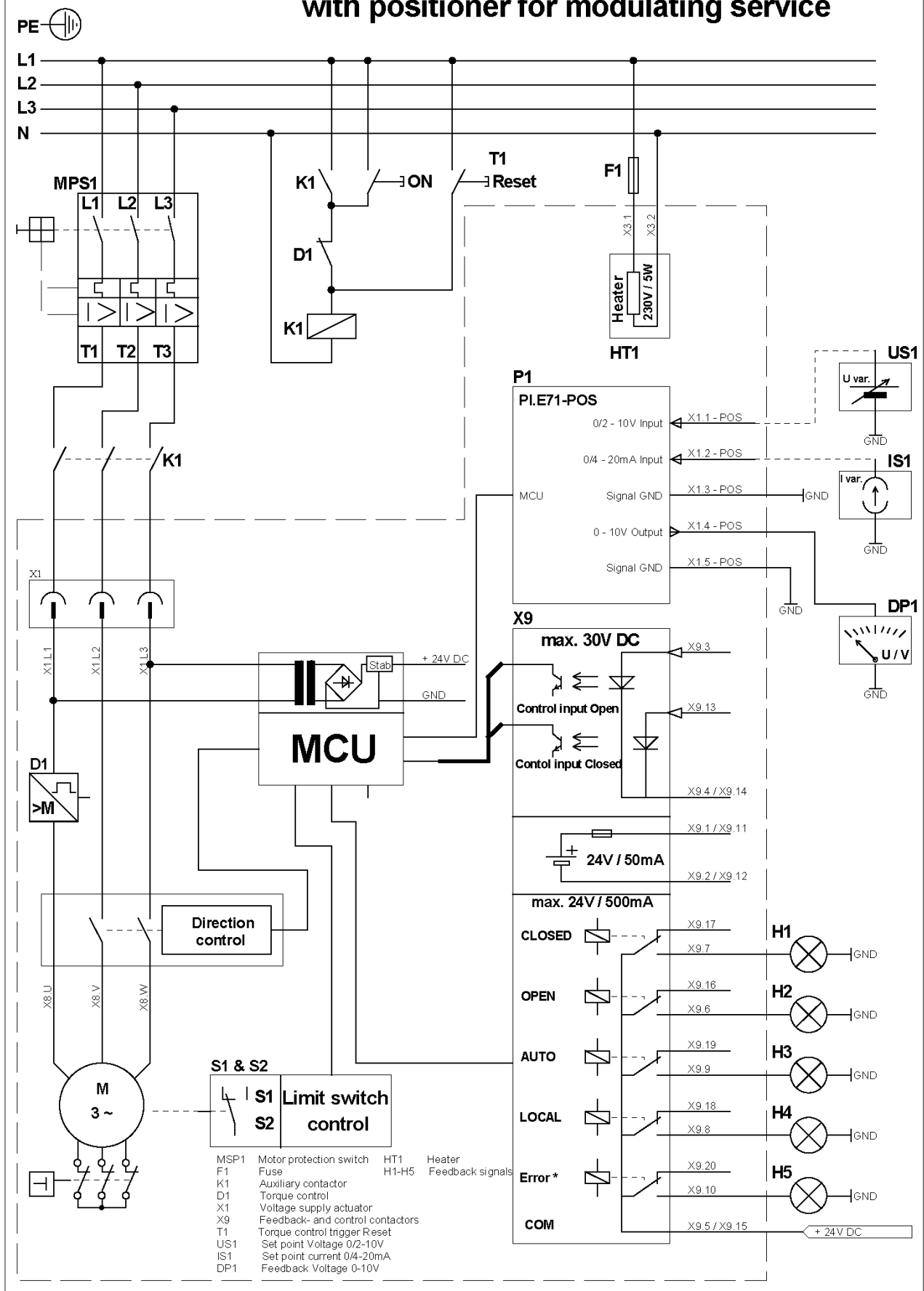

- MSP1 Motor protection switch
- F1 Fuse
- K1 Auxiliary contactor
- D1 Torque control
- X1 Voltage supply actuator
- X9 Feedback- and control contactors
- T1 Torque control trigger Reset
- US1 Set point Voltage 0/2-10V
- IS1 Set point current 0/4-20mA
- DP1 Feedback Voltage 0-10V
- HT1 Heater
- H1-H5 Feedback signals

F5 DC actuators with battery pack

Technical data for the M71-GS-XXX-40 modules

Area of usage

The quarter-turn actuators E65 GS, E110 GS and E160 GS are designed for 90° pivot paths. They are used to automate butterfly valves, ball valves and other final control elements. In addition, the enlarged switch box compartment contains an integrated battery pack. The battery pack supplies the actuator's motor in case of power loss and drives the valve into its fail-safe position. Control of the travel direction is realized by an integrated control relay. The actuators stand out due to their compact design and their practice-oriented handling in the areas of wiring system technology and commissioning. The modular construction of the actuators makes it as simple to retrofit or implement special functions. This is made possible thanks to the printed circuit board (P.C.B.), which is prepared above and beyond the standard functions to enable it to handle further components. These additional functions can, therefore, be implemented in a simple and cost-effective way.

Standard equipment

- 2 integrated travel limit switches for disconnecting travel movement without external access (S1 and S2)
- 2 additional limit switches (S3 and S4) for signalling
- Optical position indicator
- Clutch-free emergency hand wheel
- Mechanical end stops
- Switch box heater
- Integrated thermal overcurrent circuit breaker with manual reset (S7)
- Epoxy resin coating

Flanges and bushes for E65 GS

- F04, F05 and F07 according to EN ISO 5211
- Square bushes: 10 mm, 11 mm, 12 mm, 14 mm, 16 mm, 17 mm
- Round bushes: 16 mm with fitting key

Flanges and bushes for E110 GS

- F07 and F10 according to EN ISO 5211
- Square bushes: 12 mm, 14 mm, 16 mm, 17 mm, 22 mm, 24 mm
- Round bushes: 28 mm with fitting key

Flanges and bushes for E160 GS

- F10, F12 and F16 according to EN ISO 5211
- Square bushes: 17 mm, 22 mm, 24 mm, 27 mm and 32 mm
- Round bushes: 30 mm, 40 mm und 50 mm with fitting key

Options

1. Freely adjustable limit switches (S1 and S2) for limiting the angle of travel
2. Freely adjustable intermediate switches (S3 and S4) for signalling within the travel parameters
3. Potentiometer:
4. Current feedback 4–20 mA featuring dual-wire technology
5. Proximity switches for signalling
6. Special voltages

F6 Technical data

E65 GS

Actuation time from 0° to 90°	s	6		
Rated torque	Nm	100		
Rated current	A	5.5		
Starting current	A	8		
Power consumption	kW	0.077		
Rated voltage	V	24		
Frequency	Hz	-		
Duty cycle	Class B according to EN 15714-2			
Protection class	IP67 according to EN IEC 60529			
Weight in Kg	7			

E110 GS

Actuation time from 0° to 90°	s	6		
Rated torque	Nm	360		
Rated current	A	8.8		
Starting current	A	12.5		
Power consumption	KW	0.4		
Rated voltage	V	24		
Frequency	Hz	-		
Duty cycle	Class B according to EN 15714-2			
Protection class	IP67 according to EN IEC 60529			
Weight in Kg	14			

E160 GS

Actuation time from 0° to 90°	s	12		
Rated torque	Nm	800		
Rated current	A	8.8		
Starting current	A	12.5		
Power consumption	KW	0.4		
Rated voltage	V	24		
Frequency	Hz	-		
Duty cycle	Class B according to EN 15714-2			
Protection class	IP67 according to EN IEC 60529			
Weight in Kg	25			

Note:

Under normal operating conditions these actuators must be permanently supplied with power. This must be realized by the operator on-site when module M71-GS-100-40 is used. For module M71-GS-200-40, the charging of the battery pack is achieved via the delivered power supply.

The duty cycle of the actuators is dependent on the current capacity of the battery charger. For module M71-GS-200-40, this corresponds to class B (600c/h). For module M71-GS-100-40, this corresponds to the battery charge provided by the operator on-site.

The charging voltage for the battery pack is 28 V DC.

The lifespan of the battery pack is strongly influenced by the type of application. We recommend periodic inspections and a functional test at least once a year.

The loading capacity of the sealed lead acid batteries used is strongly reduced as temperatures fall. For this reason, the operating temperature for these actuators is limited to 0°C. The outdoor use of these actuators is not permitted.

In general, these actuators are manufactured for the fail-safe position “normally closed”. Should the fail-safe position “normally open” be required then this must be stated when ordering.

F7 Additional technical data

Limit switches:	max. 24 V DC, 10 A
Overcurrent circuit-breaker:	potential-free changer, max. 24V AC, 5 A
Switch box heater:	supply 24V AC permanent, 5 W
Potentiometer:	1000 Ω, 1 W, rotation angle 270°
Current feedback:	4–20 mA, supply max. 30 V DC
Thermal protection switch:	thermal overcurrent circuit breaker
Insulation class:	F
Corrosion protection class:	C4 according to EN 15714-2, tested according to EN 60068-2-52
Cable glands:	2 x M20 x 1.5; Ø min = 6 mm; Ø max = 13 mm
Operating temperature:	0°C to +70°C
Hand wheel:	15 revolutions for 90°
Hand wheel torque:	4 Nm for E65 20 Nm for E110 35 Nm for E160

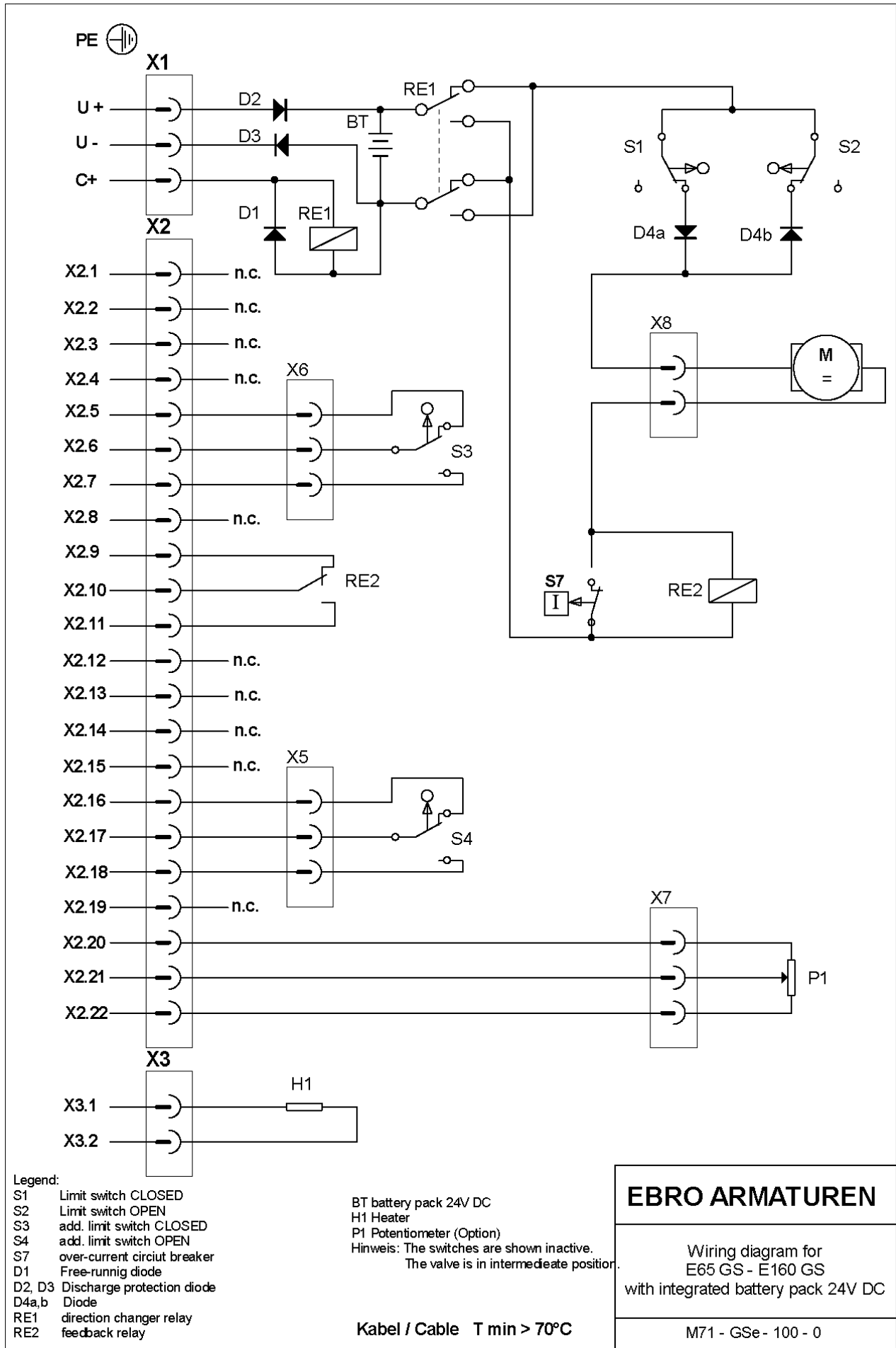

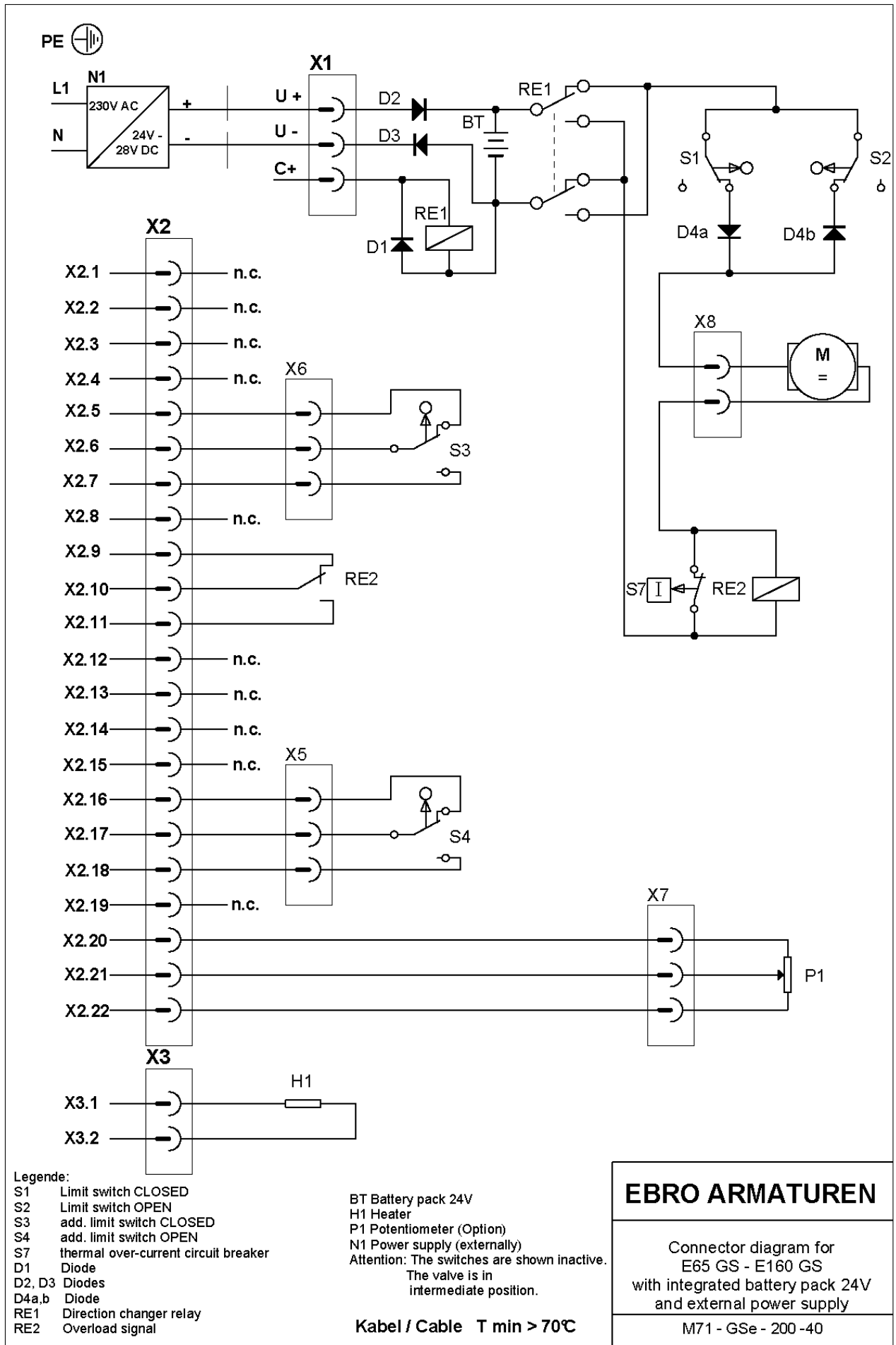

Connector table

Connector name	Function
X1.U +	24 V DC (plus) power supply; permanent
X1.U -	24 V DC (minus) power supply; permanent
X1.C+	24 V DC (plus) control for direction changer relay
X2.1	Not connected
X2.2	Not connected
X2.3	Not connected
X2.4	Not connected
X2.5	Switch S3; additional limit switch CLOSED; opener; NC
X2.6	Switch S3; additional limit switch CLOSED; floor contact; COM
X2.7	Switch S3; additional limit switch CLOSED; closer; NO
X2.8	Not connected
X2.9	Overcurrent switch status relay opener; NC
X2.10	Overcurrent switch status relay floor contact; COM
X2.11	Overcurrent switch status relay closer; NO
X2.12	Not connected
X2.13	Not connected
X2.14	Not connected
X2.15	Not connected
X2.16	Switch S4; additional limit switch OPEN; opener; NC
X2.17	Switch S4; additional limit switch OPEN; floor contact; COM
X2.18	Switch S4; additional limit switch OPEN; closer NO
X2.19	Not connected
X2.20	Potentiometer; end contact or current feedback current output
X2.21	Potentiometer, collector bar
X2.22	Potentiometer; or current feedback voltage input
X3.1	Switch box heater; supply voltage 24 V permanent
X3.2	Switch box heater; supply voltage 24 V permanent

Replacement parts: EST order code

	Size	Voltage	Assembly	Actuating time	Consecutive number
EST-	YYY	YYY	YY	YY	YYYY

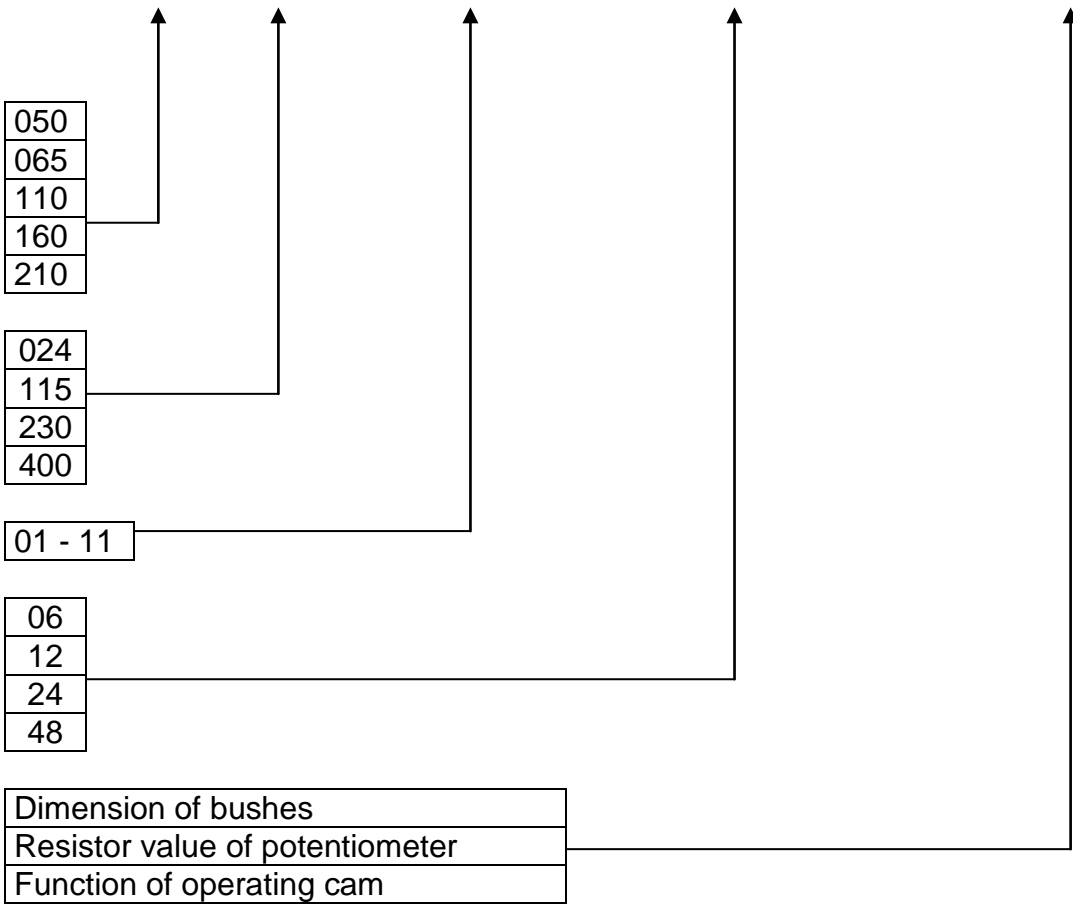

Example:

EST-110-230-08-12-0000

Torque cut-off for E110 WS with 12 s actuation time

The manufacturer	EBRO ARMATUREN Gebr. Bröer GmbH, D58135 Hagen, Germany
declares that the EBRO electrical quarter-turn actuators “Type E50 to E210” comply with the following provisions	
Requirements according to appendix I of the Machinery Directive 2006/42/EC	
1.1.1., g) Correct use	Original – Assembly Instructions with Operating Instructions
1.1.2., c) Incorrect use warnings	Original – Assembly Instructions with Operating Instructions
1.1.2., c) Required protective equipment	Exactly the same as for the system in which the actuator is installed
1.1.2., e) Accessories	No special tool is required for changing worn parts
1.1.5 Handling	Fulfilled through the “Original – Assembly Instructions with Operating Instructions”
1.2 and 6.2.11 Control	The user’s responsibility; must be in accordance with the operating instructions for the actuator
1.3.4 Sharp corners and edges	Requirement fulfilled
1.3.7/8 Injury caused by moving parts	Requirement fulfilled if correctly used. Service and repair are only permissible with actuator deactivated and power supply switched off.
1.5.1–1.5.3 Power supply	The responsibility of the user. See also the operating instructions for the actuator.
1.5.5. Operating temperature	Warning notice against unacceptable temperatures: See operating instructions, section <hazard warnings>
1.5.7 Explosion	Not applicable
1.5.13 Emission of hazardous substances	Not applicable, provided the actuator is operated as intended
1.6.1 Servicing	Maintenance-free under normal use.
1.7.3 Identification	On the type plate, see “Original – Assembly Instructions with Operating Instructions”
1.7.4 Operating instructions	Requirement fulfilled
Requirement according to appendix III	The actuator is not a <complete machine>: therefore it has no CE marking for conformity according to the Machinery Directive
Requirements according to appendix IV, VIII–XI	Not applicable
Requirements according to prEN 12100:2009	
1. Area of application	The product standard prEN 15714-2: < Electrical quarter-turn actuators for industrial valves> was used as basis for the analysis together with an actuator as per EN15714-2. Also the >10 years of experience using the above-mentioned types of actuator. <i>Note: It must be assumed that the planner/operator will perform a risk analysis for the pipe section including the actuators used in it, which is specifically tailored to the operating case, in accordance with sections 4 to 6 of EN 12100 – such an analysis is not possible for the manufacturer EBRO-ARMATUREN in the case of standard actuators.</i>
3.20.6.1 Inherently safe design	The actuators are manufactured according to <inherently safe design> principles.
Analysis according to sections 4, 5 and 6	Experience of faulty operation and misuse documented by the manufacturer in the context of cases of damage (documentation in accordance with ISO9001) was used as the basis.
5.3 Limits of the machine	Limiting of the incomplete machine was carried out in accordance with the <correct use> of both the valve and the actuator.
5.4 Decommissioning, disposal	Not within the responsibility of the manufacturer
6.2.2 Geometric factors	Since the valve and actuator comprise the functional parts of the valve when correctly used, this section does not apply.
6.3 Technical protective devices	None, in compliance with the valid VDE regulations and the instructions from the “Original – Assembly Instructions with Operating Instructions”.
6.4.5 Operating instructions	As valves with actuators work automatically according to the command signals from the controller, the operating manual describes those aspects that are <relevant for the actuator> and must be provided to the manufacturer of the piping system.
7 Risk analysis	The risk analysis was carried out in accordance with MRL appendix VII, B) by the manufacturer, EBRO and is documented in accordance with MRL appendix VII B).